

HAND **SANITIZING** STATION



The Hand Sanitizing Station is a versatile sanitizing solution, designed for **high traffic** commercial, industrial and public spaces.

It has the unique ability to handle a very high volume of traffic with **up to 5,000 uses** between refills.

HAND SANITIZING STATION

Rugged aluminum construction suitable for harsh high traffic environments

Drip tray protects floor surfaces

Additional space at bottom of cabinet for a refill bottle or pail

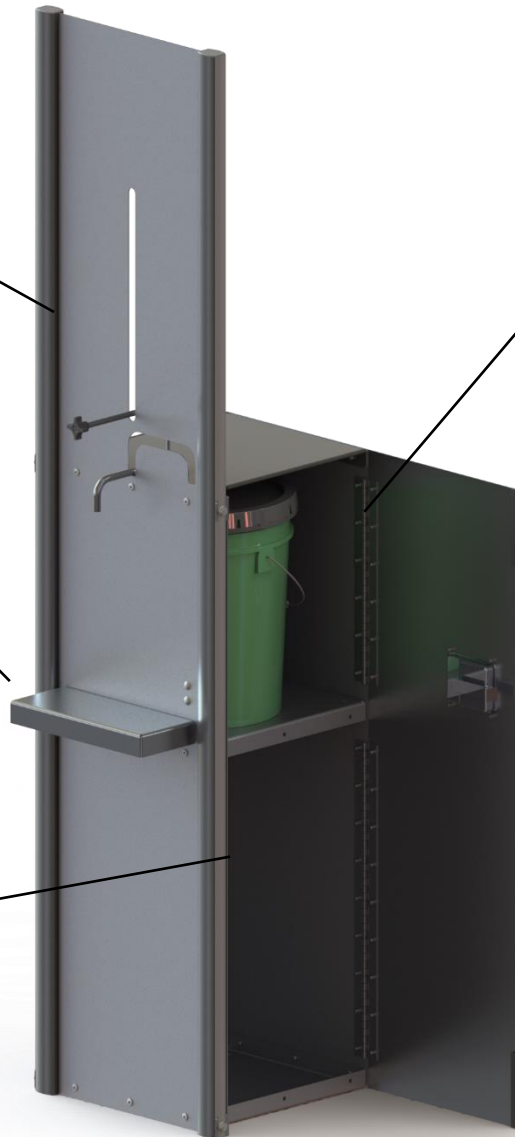

Accepts various sizes of refill including most standard half gallon (2L) and 1 gallon (4L) bottles, and 5 gallon (23L) pails

Keyed lock restricts access

SKU	Description
RM-100	Hand Sanitizing Station

Delivery anywhere in US or Canada. Minimum 10 units

HAND SANITIZING STATION

Specifications: Dimensions in inches

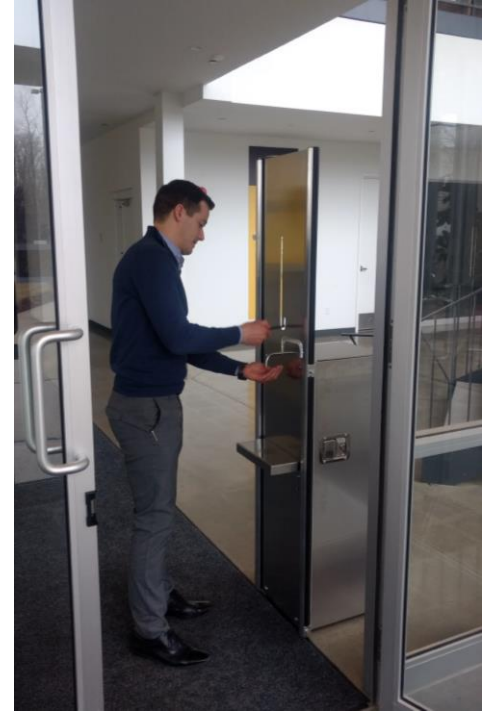
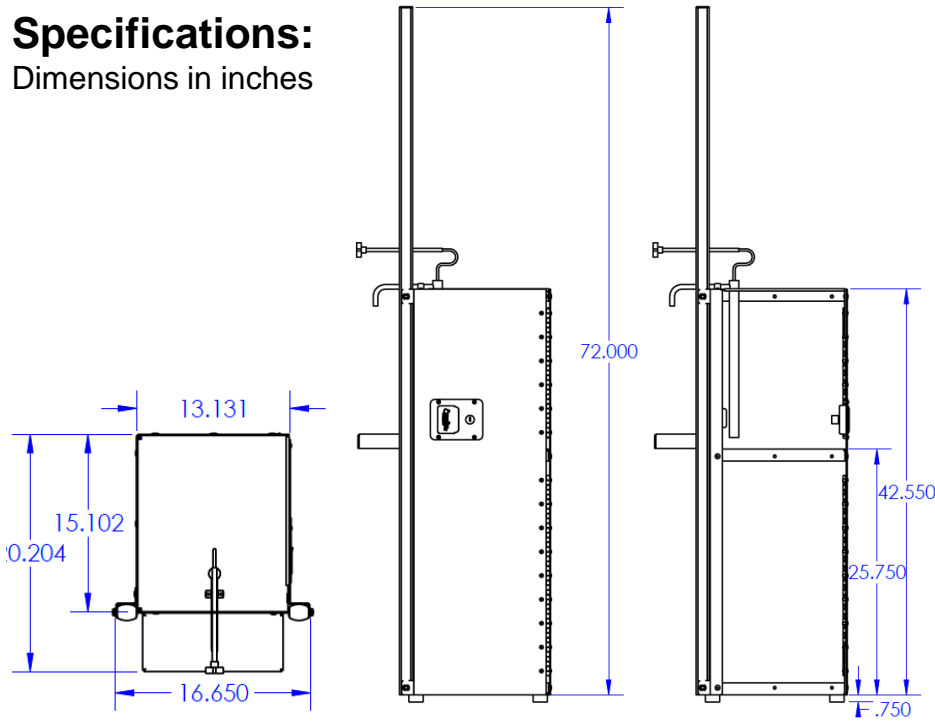

Typical Applications:



HAND **SANITIZING** STATION

About Ranger Design:

Founded in 1988, Ranger Design is an ISO certified manufacturer with multiple manufacturing capabilities and high volume capacity.



Inquire about other items in our range:



IV Poles



Medical Cabinets

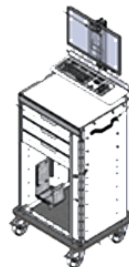

Emergency Response Beds



CUSTOMER SERVICE

cs@rangerdesign.com

1-800-565-5321

rangerdesign.com



P20RM100V1