

INSTALLATION GUIDE



X50-B and X50-C

Fleetline Compact 2 and 3 Drawer Unit



SAFETY INSTRUCTIONS

Before the installation, carefully read the supplied installation guide to avoid possible injuries and damages resulting from incorrect installation. Always keep the installation guide in an accessible location at all times for reference during installation.

WARNING

- Only a qualified person/s should install this product.
- This product requires 1 person to install.
- Always use safety gloves, glasses, and shoes.



1
PERSON

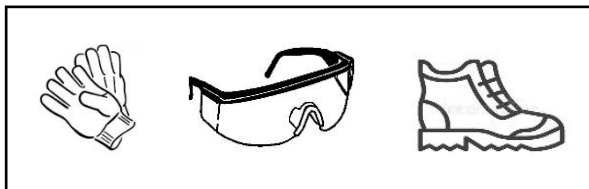

CAUTION

- Follow all vehicle manufacturer instructions before attempting any installation.

PREPARATION

Tools Needed

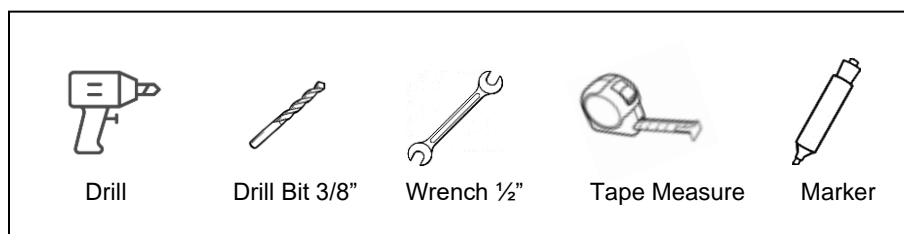

BILL OF MATERIALS

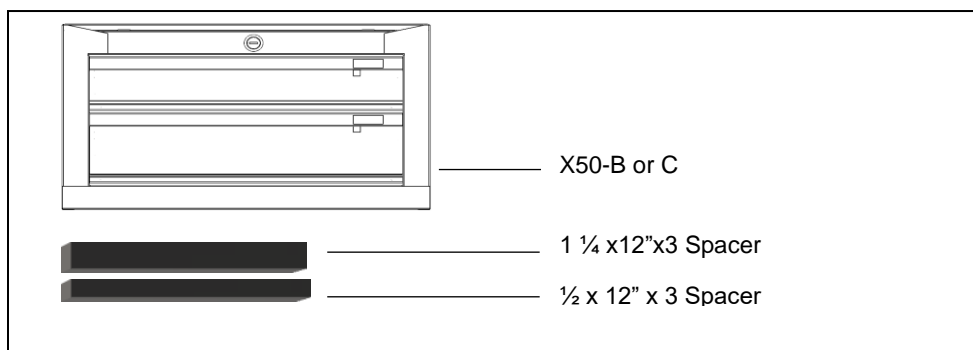

Bill of Materials

| Item No. | Description | Qty. |
|-----------------|--------------------------------------|------|
| X50-B or X50-C | Fleetline Compact 2 Or 3 Drawer Unit | 1 |
| 1/2 x 12" x 3 | Spacer | 2 |
| 1 1/4 x 12" x 3 | Spacer | 2 |

Hardware Kit

| Item No. | Description | Qty. |
|----------|--------------------------|------|
| | M8 SPRING WASHERS | 6 |
| | M8 X 32 MM HEX HEAD BOLT | 6 |
| | M8 X 65MM CARRIAGE BOLT | 6 |
| | M8 SERRATED FLANGED NUT | 6 |

ASSEMBLY- Stacking Units (Optional)

STEP 1

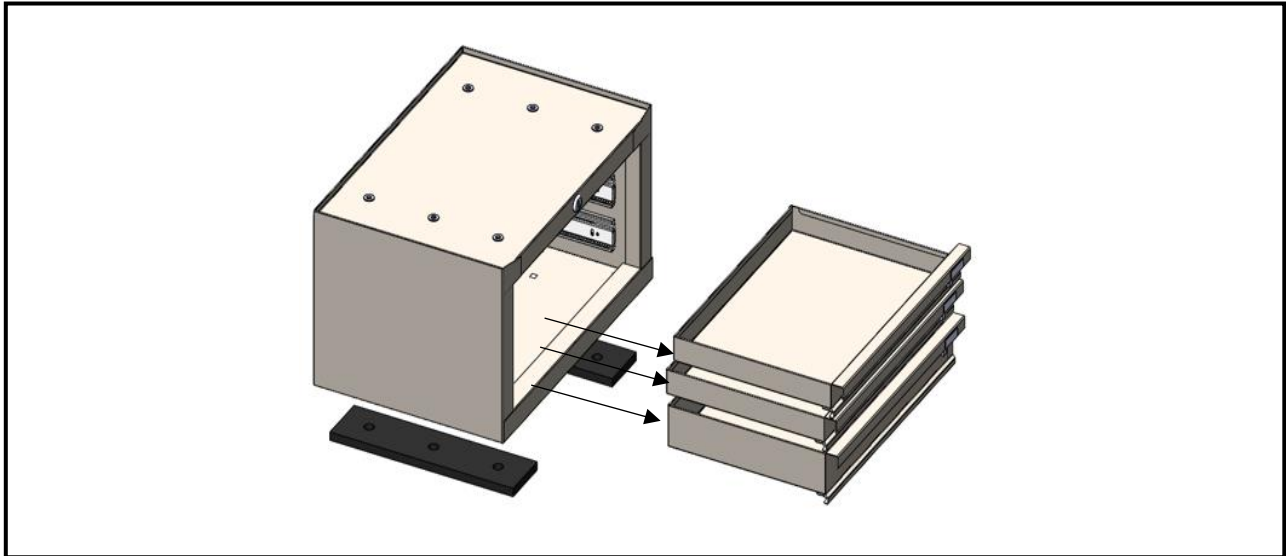

STEP 2

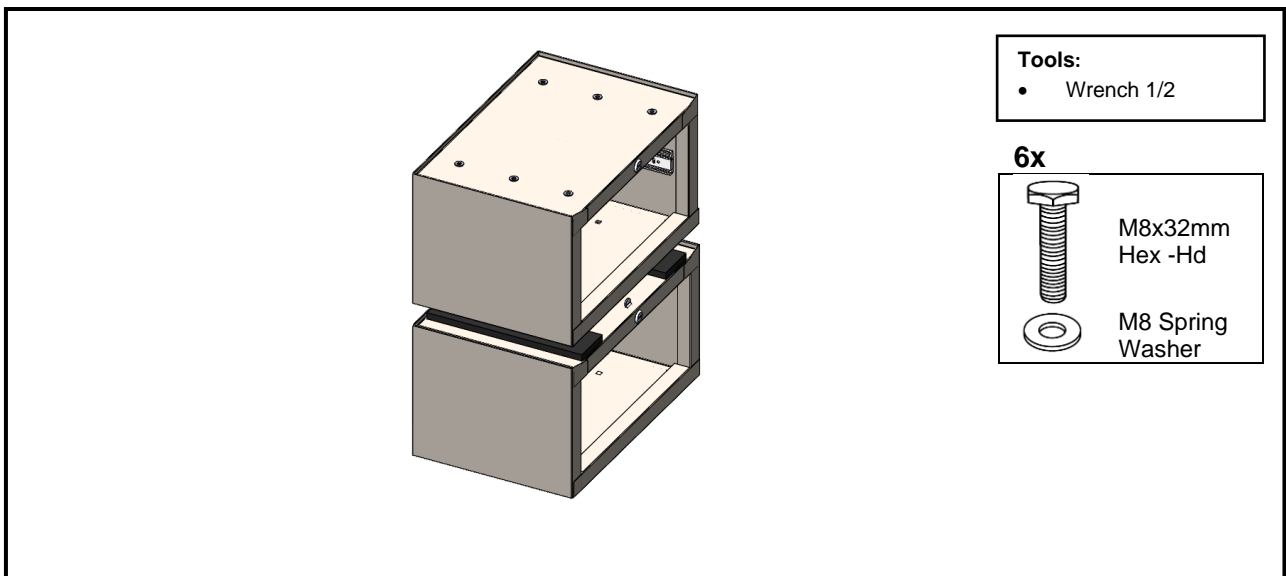

ASSEMBLY- Shelving Installation

STEP 3

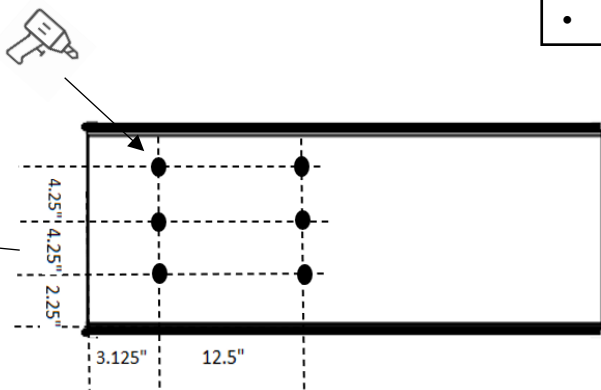
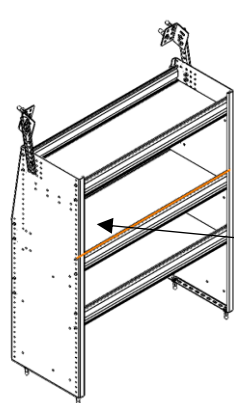

Tools:

- Drill
- Drill Bit 5/16"

STEP 4

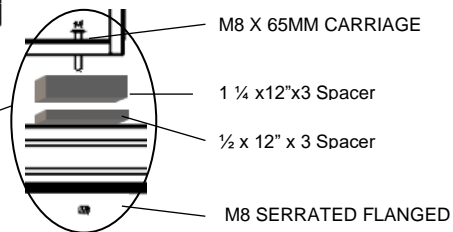
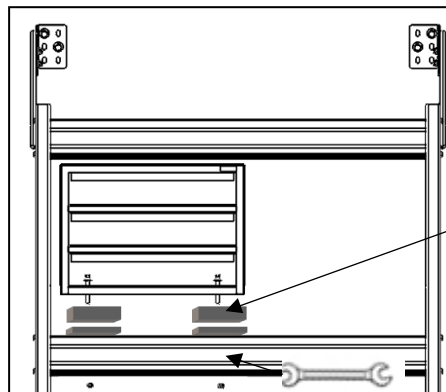

Tools:

- Wrench 1/2"

6x



Carriage bolt
M8x65mm"



Srr-flg nut
M8

“You have successfully installed your X50-B or X50-C, thank you for doing business with us.”

For any feedback or suggestions, you may have, please contact: cs@rangerdesign.com

