

# INSTALLATION GUIDE

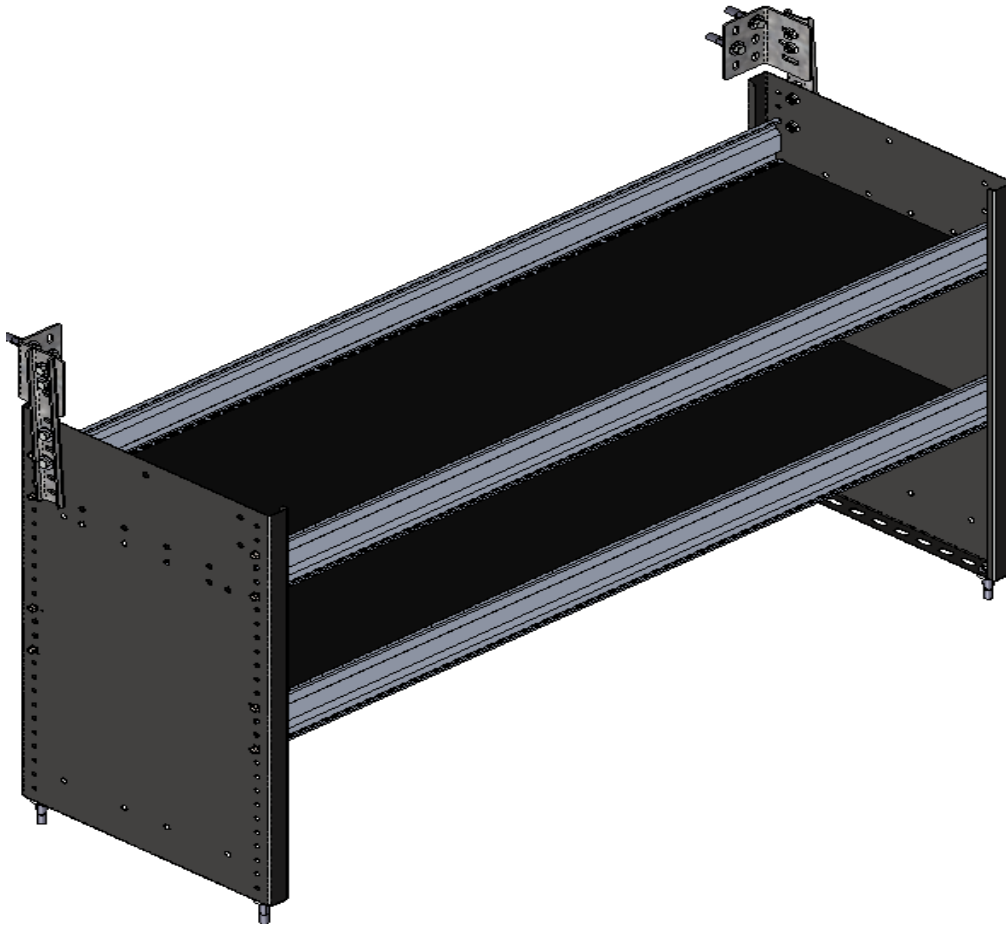

## S2-RS48-2 Shelving ( STEEL )

Ram C/V

Box Truck / Trailer

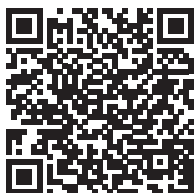

Scan the QR for the latest Install-Guide.





# BEFORE YOU BEGIN

READ, UNDERSTAND, AND FOLLOW ALL WARNINGS AND INSTRUCTIONS BEFORE USING THIS PRODUCT. FAILURE TO FOLLOW THESE DIRECTIONS MAY RESULT IN PROPERTY DAMAGE, SERIOUS BODILY INJURY, AND/OR DEATH. RANGER DESIGN IS NOT RESPONSIBLE FOR ANY PROPERTY DAMAGE, PERSONAL INJURY, OR DEATH THAT OCCURRED WHILE USING ANY RANGER DESIGN PRODUCTS.



## WARNING

- Failure to use Ranger Design-provided fasteners, brackets, and proper installation guidelines could increase risk of serious personal injury and/or death.
- If drilling is required to complete this installation: improper drilling can cause property damage to vehicles and could lead to electric shock, fire, or even death.
- If drilling is required to complete this installation: Ensure that drilling is only performed on areas of the vehicle allowed by the vehicle's Original Equipment Manufacturer's Body Builders Layout Book (or equivalent document).
- Prior to installation, inspect the vehicle to ensure that installation will not interfere with, or cause obstruction of, any critical components such as electrical wiring, fuel tanks, fuel-cells, locks, latches, etc.
- The installer or manufacturer is responsible for ensuring anchorages are installed onto suitable wall and floor structures; wall and floor strength must meet applicable performance requirements.
- Do not install systems into any weak or unsound materials such as plastics, woods, thin-walled metals, etc. without proper reinforcement.
- Do not install this product where it could interfere with the deployment of airbags. Failure to comply could result in death or serious injury.
- Do not install this product where it could ingress on the Transit Occupant Protection Zone. Failure to comply could result in death or serious injury.
- Incorrect installation could cause water leaks, electric shock or fire.
- Any cargo vehicle with any cargo or equipment should use a certified partition. See Ranger Design website for some partition options. (<https://rangerdesign.com/>)
- Mountings rails are recommended for any attachment to the vehicle walls.
- All items in the cargo area should be properly secured and partition doors closed while the vehicle is in motion.
- Check your vehicle's tare weight and remaining load capacity with all the equipment installed. Never exceed the maximum Gross Vehicle Weight Rating (GVWR), Gross Axle Weight Ratings (GAWRs), or other maximum loads permitted by the vehicle's Original Equipment Manufacturer (OEM) and required by law.
- The heaviest items must be placed towards the bottom of the vehicle, while the lightest ones can be arranged upwards. Vehicle cargo loading weight proportion should follow the following guidelines:

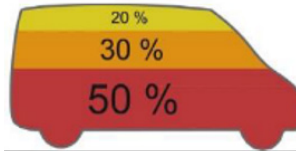

- The final alterer and/ or modifier should review the warning sheet with the customer before the vehicle is released to the customer or for general use. These instructions should remain with the vehicles a all times.
- Any modification or unintended use of this product voids any warranty and could create a hazardous condition.
- Ranger Design provides recommended assembly and installation instructions which should be followed to ensure correct operation. Failure to do so could result in invalidating the product's compliance, warranty and cause injury. Notwithstanding, the final stage vehicle alterer and/or modifier is responsible for the integration, installation, and compliance of the product in its final location to all applicable regulations and standards. Failure to maintain compliance of the vehicle to applicable regulations and standards could be punishable by law. Alterers and/or modifiers should consult with all local authorities prior to commissioning.



## CAUTION

- Drilling is required to complete this installation. Before drilling, ensure that you will not hit any critical parts of the vehicle like the gas tank, wiring harness, or hose. Consult the vehicle OEM documentation as necessary. When drilling, use a drill collar to reduce the risk of damage to the vehicle.
- Any materials, padding, or glazing installed in the vehicle must comply with FMVSS/CMVSS 201/205/302, as applicable.
- In the event of a motor vehicle accident or collision where a Ranger system has been installed, especially ones where the vehicle structure is damaged and/or the air bags deploy and/or the vehicle has been towed, the system must be inspected to ensure continued soundness and safety before returning the vehicle to service. Damaged components should be replaced as necessary.
- All system components should be regularly inspected, cleaned, and maintained pursuant to Ranger guidelines.

# QUICK START GUIDE

## Phase 1 - Assembly

<input type="checkbox"/> 1.1 Setup.....	4
<input type="checkbox"/> 1.2 Shelf Assembly.....	6

## Phase 2 - Installation

<input type="checkbox"/> 2.1 Attach Wall Brackets To The End Panels.....	8
<input type="checkbox"/> 2.2 Mark Holes For Plus Nuts.....	9
<input type="checkbox"/> 2.3 Attach Plus Nut.....	10
<input type="checkbox"/> 2.4 Attach Shelf Unit To the Floor.....	12
<input type="checkbox"/> 2.5 Attach Wall Brackets.....	13

# REQUIRED ITEMS

- Cordless Impact
- Cordless Drill
- Tape Measure
- Marker
- 1/2" Socket
- 1/2" Drill Bit w/ Drill Collar ( Set at 1/2" )
- 3/8" Driver Bit
- Knife
- Plusnut Tool / Plusnut Gun ( 5/16" )

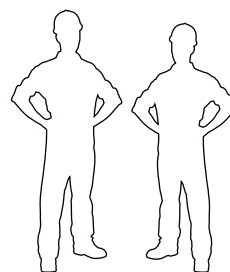

**2**  
**PERSONS**

# PHASE 1 – ASSEMBLY

## 1.1 SETUP

1.1.1 Unpack components; compare with the bill of materials.

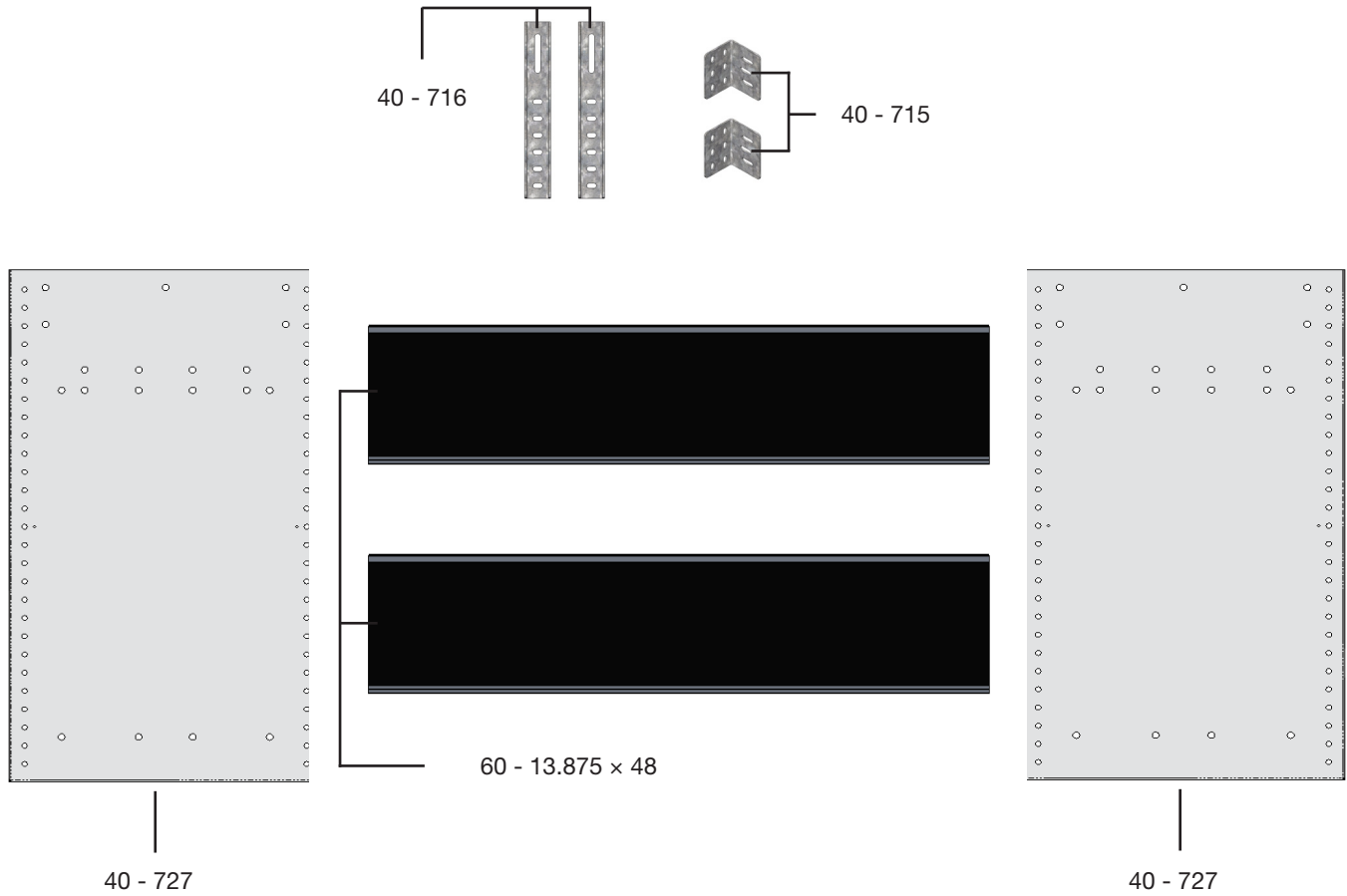

1.1.2 Verify all parts are present.

### BILL OF MATERIALS

Item No.	Description	Qty.
40 - 715	Bracket head	2
40 - 716	Bracket arm	2
40 - 727	End Panel	2
60 - 13.875 x 48	Shelf Tray, Black Plywood, Usable 14" x 48"	2
94 - 4029	Assembly Fastener Kit	1
96 - 4027	Install Fastener Kit	1

1.1.3 Fastener kits.

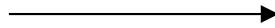

**94 - 4029 Fastener Kit**



**Fastener Assembly**

- 8x  # 90-204 Hex Bolt  
5/16"-18 x 3/4"  
GR-5 ZINC
- 16x  # 92-102 Screw HWH  
#14 x 1"  
ZINC
- 8x  # 94-116 Serrated Nut  
5/16"-18  
ZINC
- 8x  # 98-116 Flat Washer  
5/16" - 18 x 1"  
ZINC

8x

 #90-204 Hex Bolt 5/16" x 3/4"  
 #98-116 Flat Washer  
 #94-116 Serrated Nut





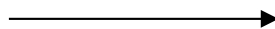

16x

 #92-102 Screw #14 x 1"





**96 - 4027 Fastener Kit**







**Fastener Assembly**

- 4x  # 90-011 Hex Bolt  
5/16"-18 x 1-3/4"  
GR-5 ZINC
- 4x  # 90-212 Hex Bolt  
5/16"-18 x 1-1/4"  
GR-5 ZINC
- 8x  # 94-132 Plusnut
- 8x  # 98-116 Flat Washer  
5/16", O.D. 7/8"  
ZINC
- 8x  # 98-122 Lock Washer  
5/16"  
ZINC
- 4x  # 98-157 Spacer  
0.375" ID, x 1.0" OD x 0.25" LONG  
NYLON

4x

 #90-212 Hex Bolt 5/16" x 1-1/4"  
 #98-122 Lock Washer  
 #98-116 Flat Washer  
 #94-132 5/16" Plusnut

4x

 #90-011 Hex Bolt 5/16" x 1-3/4"  
 #98-122 Lock Washer  
 #98-116 Flat Washer  
 #98-157 Spacers  
 ( QTY = GAP BETWEEN FLOOR AND END PANEL )  
 #94-132 5/16" Plusnut

# PHASE 1 – ASSEMBLY

## 1.2 SHELF ASSEMBLY

1.2.1 Attach both panels to the shelf trays.

**NOTE:** You can adjust the bottom shelf location to maximize or minimize your space over the wheel.

**IMPORTANT:** Always handle panels on a smooth, protected and clean surface to avoid unnecessary scratching.

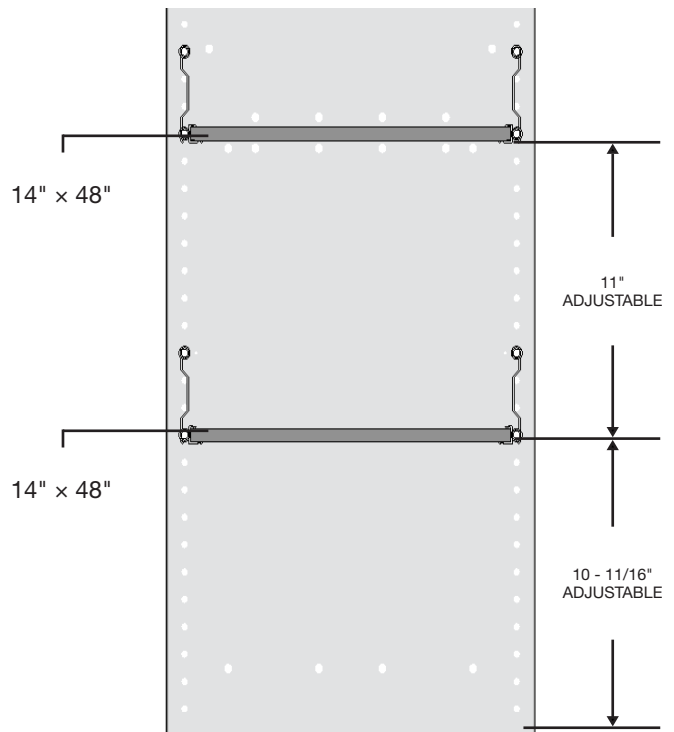
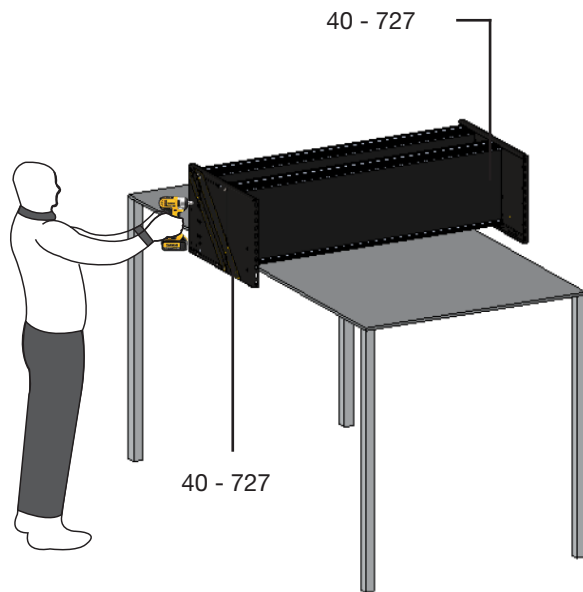

A close-up photograph showing a black panel being attached to a shelf tray. Two screws are shown being inserted into the panel. The screws are labeled '#92-102 Screw #14 x 1"'. The panel is labeled '40 - 727'.

**TOOLS**

- Cordless Impact
- 3/8" Driver Bit

**HARDWARE USED**

**16x**

#92-102 Screw #14 x 1"

1.2.2 Attach the bracket head to the bracket arm.

**NOTE:** Hand-tighten the bolts for adjustment.

**2x**

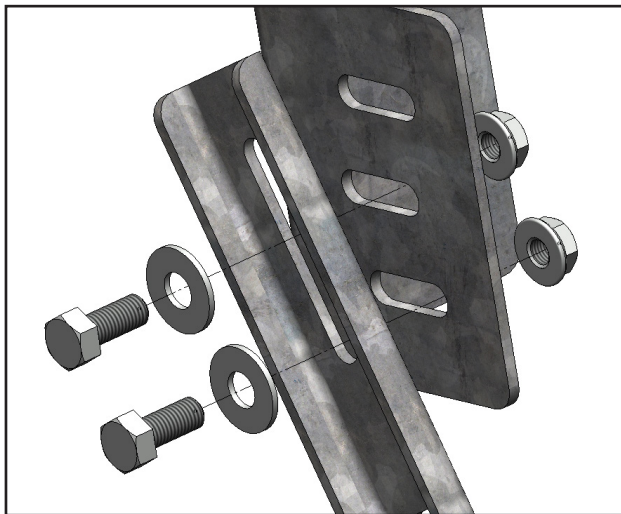
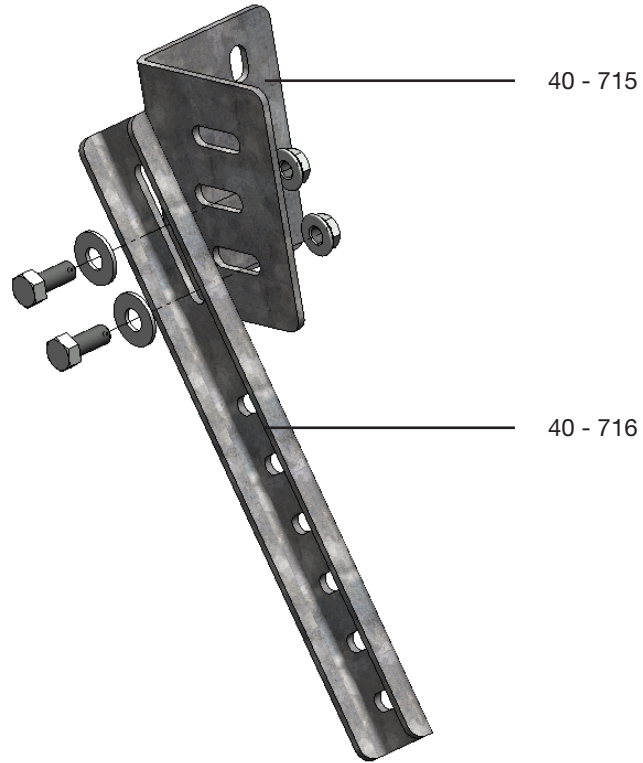



**TOOLS**

- Cordless Impact
- 1/2" Socket

**HARDWARE USED**

**4x** HAND-TIGHTEN THE BOLTS

- |  |                               |
|--|-------------------------------|
|  | #90-204 Hex Bolt 5/16" x 3/4" |
|  | #98-116 Flat Washer           |
|  | #94-116 Serrated Nut          |

# PHASE 2 – INSTALLATION

## 2.1 ATTACH WALL BRACKETS TO THE END PANELS

- 2.1.1 • Lift the assembled shelf to the vehicle with care, then put it in place.  
• Attach the bracket arm to the panels aligning the brackets head to the structure of the van or truck.

**IMPORTANT:** For **Box Trucks** and **Ram C/V**, make sure that the shelving is securely fastened to the structure of the truck or van.

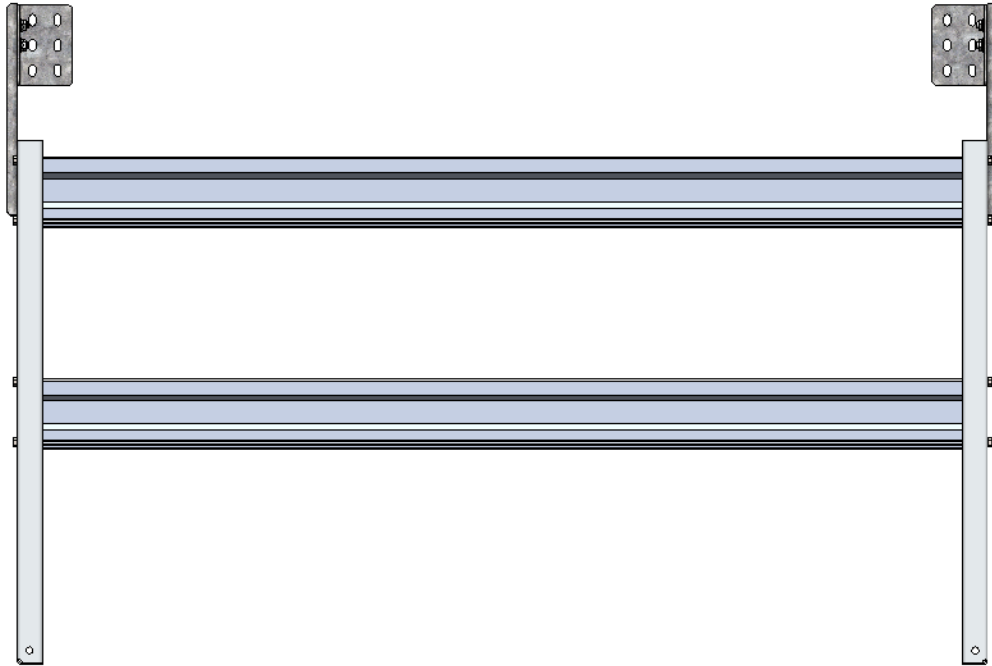

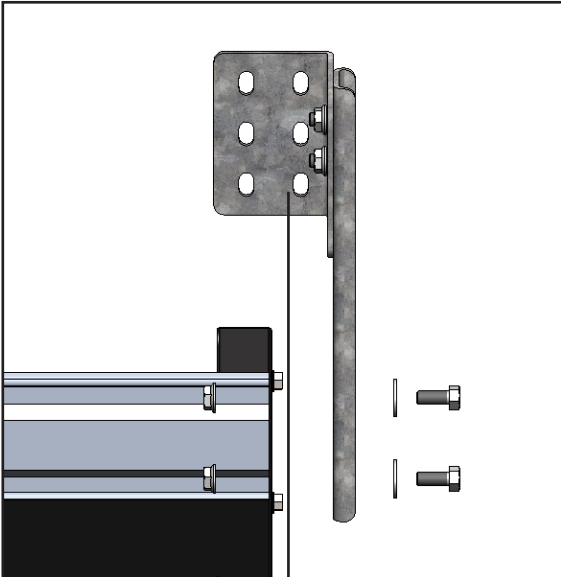



The diagram shows a close-up of the bracket head assembly. A vertical metal arm is attached to a horizontal shelf. The bracket head is a rectangular plate with four holes. Two bolts are shown passing through the holes in the bracket head and into the shelf. The bolts are secured with flat washers and serrated nuts. The shelf is shown in a light blue color, and the bracket head is in a light grey color.

**TOOLS**

- ☐ Cordless Impact
- ☐ 1/2" Socket

**HARDWARE USED**

**4x** HAND-TIGHTEN THE BOLTS

	#90-204 Hex Bolt 5/16" x 3/4"
	#98-116 Flat Washer
	#94-116 Serrated Nut

BRACKET HEAD



# PHASE 2 – INSTALLATION

## 2.2 MARK HOLES FOR PLUS NUTS

2.2.1 After attaching the brackets mark the holes on the brackets and end panels to the structure of the truck or van.

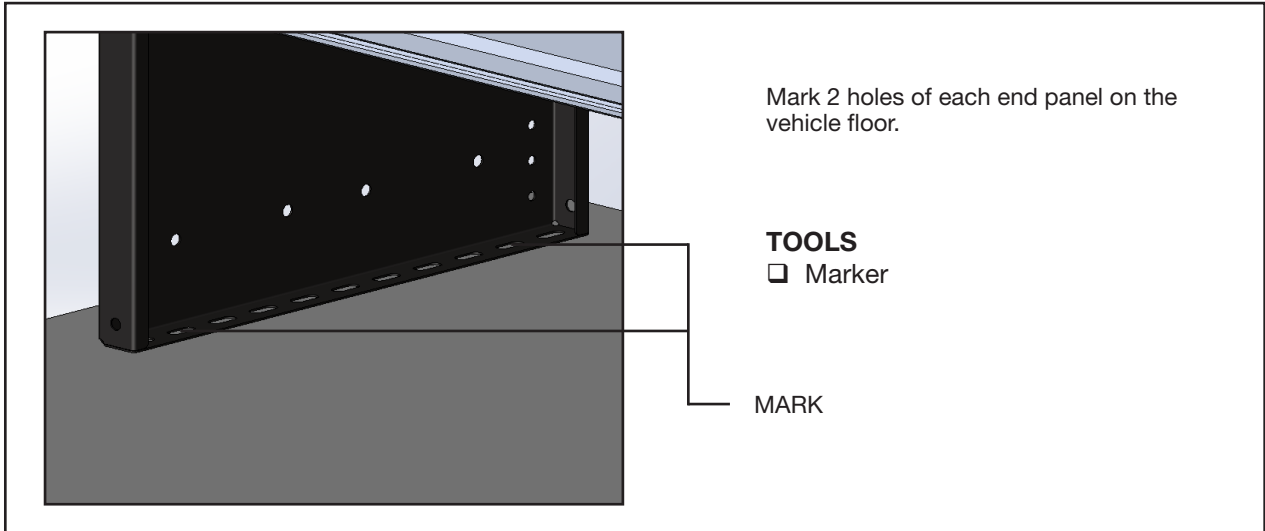
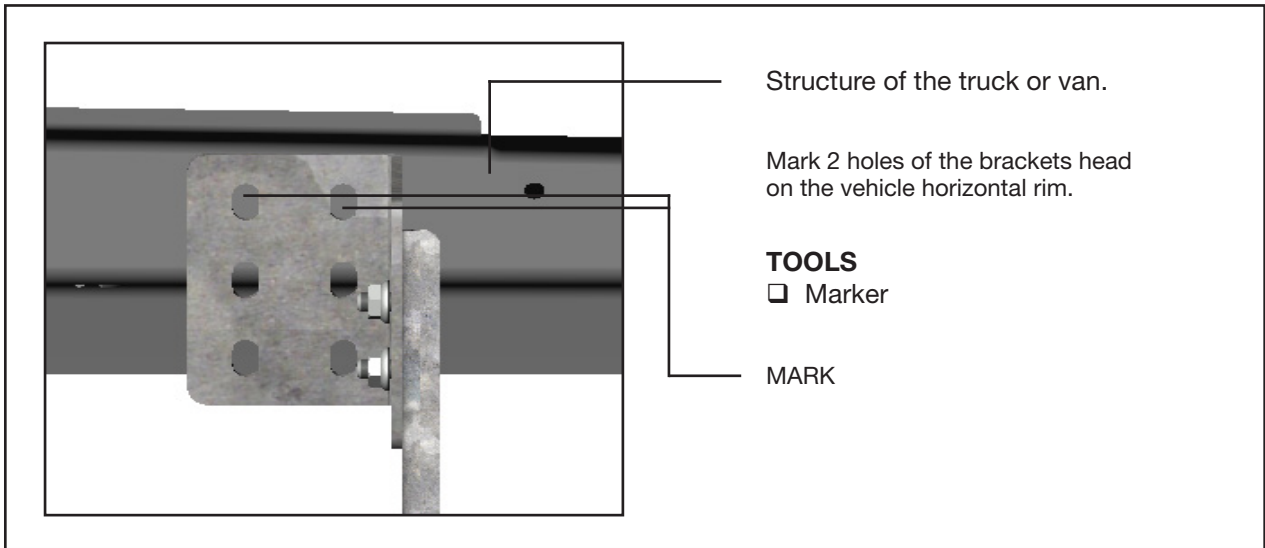
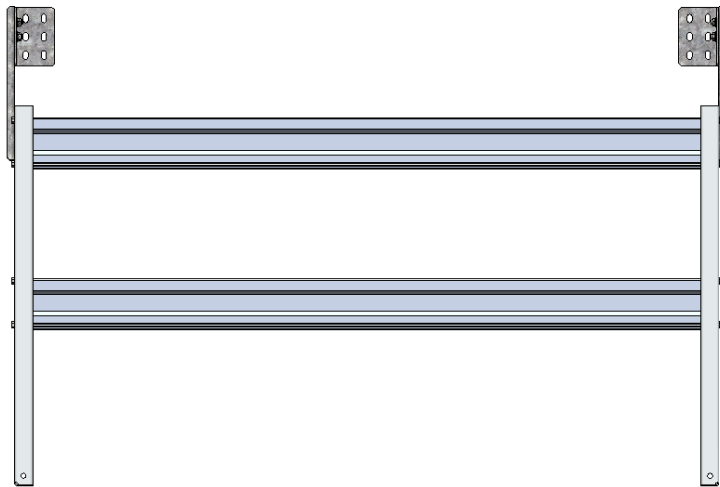

# PHASE 2 – INSTALLATION

## 2.3 ATTACH PLUS NUTS

- 2.3.1 • Lift the assembled shelf on the side.  
• Drill all the marks using 1/2" drill bit w/ drill collar, then attach plus nuts to the holes.

**NOTE:** Use 1/2" drill bit with drill collar to stop drill at 1/2" depth.

**WARNING:** Before drilling, ensure that you will not hit any critical parts of the vehicle like the **Gas tank**, **Wiring Harness** and **Hose**.

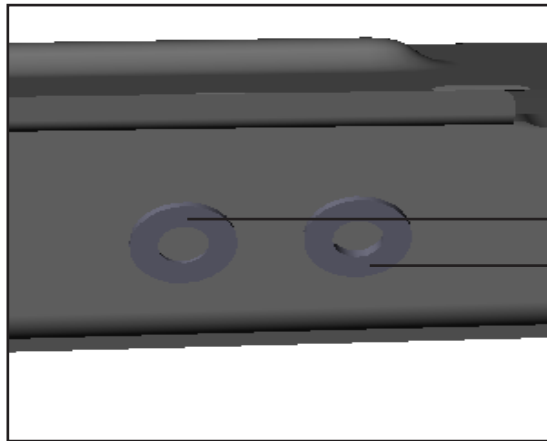
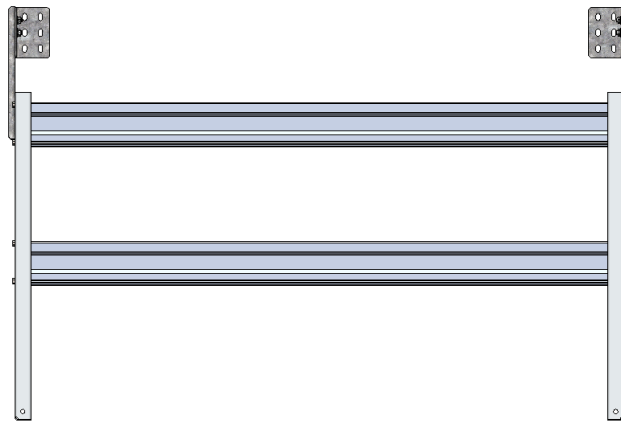

### PLUSNUT

Drill all the marks then, attach plus nuts to the holes.

### TOOLS

- Cordless Drill
- 1/2" Drill Bit w/ Drill Collar ( Set at 1/2" )
- Plus Nut Tool ( 5/16" )

### HARDWARE USED

8x



#94-132 Plus Nut

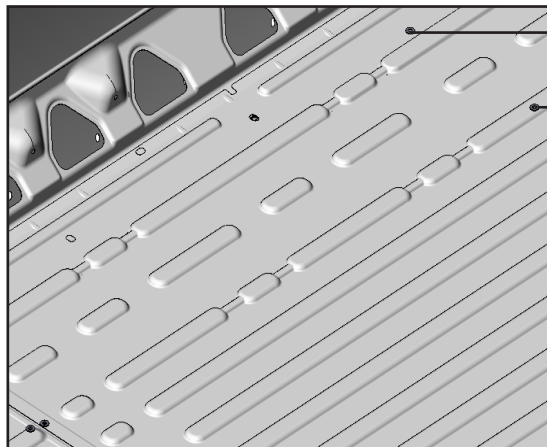

DRILL COLLAR  
( SET AT 1/2" )

### 2.3.2 How to attach plus nut.

#### • USING PLUSNUT GUN

**STEP:** Put the plusnut on the plusnut gun, then attach the plus nut in the hole by turning the gun forward until the plus nut locks, then remove the gun by turning in reverse.

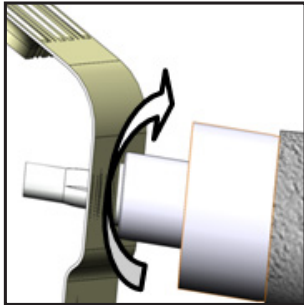

**FORWARD**

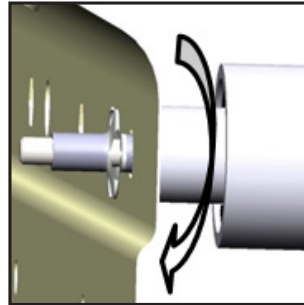

**REVERSE**

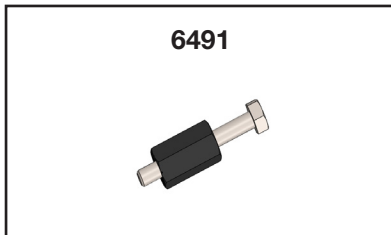

#### • USING THE 6491 PLUSNUT TOOL

**NOTE:** The hardware used for the 6490 plusnut tool is not included in the fastener bag.  
The 6490 plusnut tool can be ordered separately upon demand at no charge.



**6491**

#### HARDWARE USED

-  Flat washer 5/16"
-  Flat washer 5/16" BS × 7/8" OD

#### TOOLS

- Cordless Impact
- 1/2" Socket
- 9/16" Wrench

#### STEP 1:

Assemble the 6491 plusnut tool with the hardware needed, plus nut and the 9/16" wrench as shown.



#### STEP 2:

Attach the plus nut in the hole by turning the bolt forward using an impact with a 1/2" socket until the plusnut locks, then remove the bolt by turning the impact in reverse.

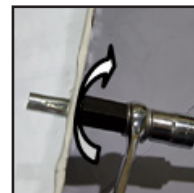

**FORWARD**



**REVERSE**

# PHASE 2 – INSTALLATION

## 2.4 ATTACH SHELF UNIT TO THE FLOOR

**2.4.1** Put the assembled shelf back in place aligning the holes to the plusnuts, then install the end panels to the plus nuts.

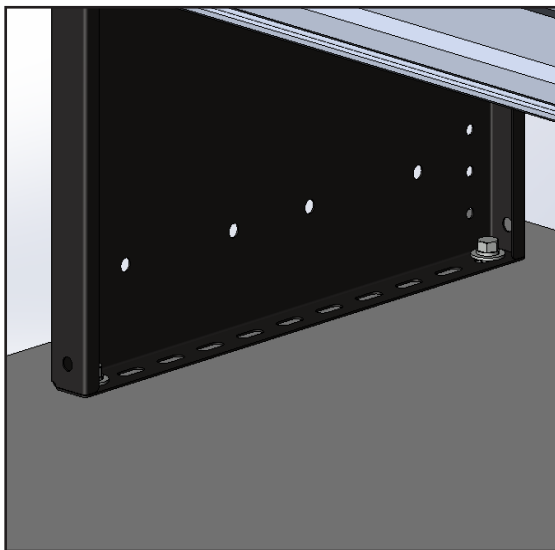
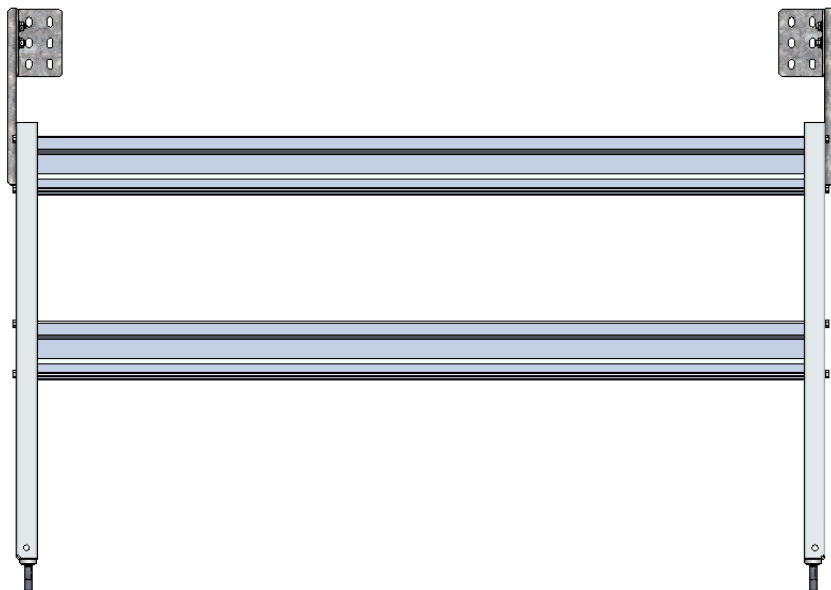

### TOOLS

- ☐ Cordless Impact
- ☐ 1/2" Socket

### HARDWARE USED

**4x**



#90-011 Hex Bolt 5/16" x 1-3/4"



#98-122 Lock Washer



#98-116 Flat Washer



#98-157 Spacers

( QTY = GAP BETWEEN FLOOR AND END PANEL )



#94-132 5/16" Plusnut

MOST VEHICLE USE 1 SPACER WHEN NOT OVER RIBS

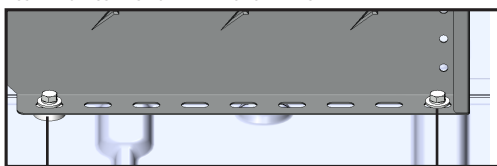

W/ Spacer

W/O Spacer

# PHASE 2 – INSTALLATION

## 2.5 ATTACH WALL BRACKETS

**2.5.1** Aligned the wall brackets to the plus nuts, then install the wall brackets to the structure of the truck or van.

**NOTE:** Tightened the bolts that used to attached the wall bracket to the structure of the truck or van 1<sup>st</sup> before the bolts that used to attached the wall bracket to the end panel.

**IMPORTANT:**

- For **Box Trucks** and **Ram C/V**, make sure that the shelving is securely fastened to the structure of the truck or van.
- After installation is completed, ensure all bolts are tightened.

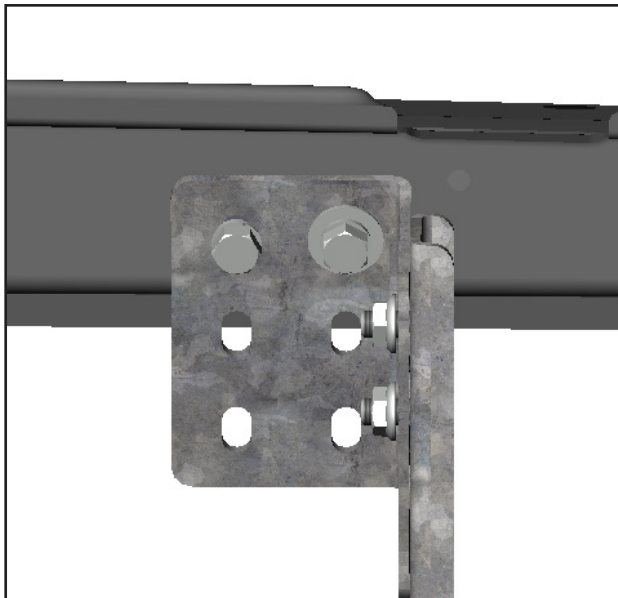
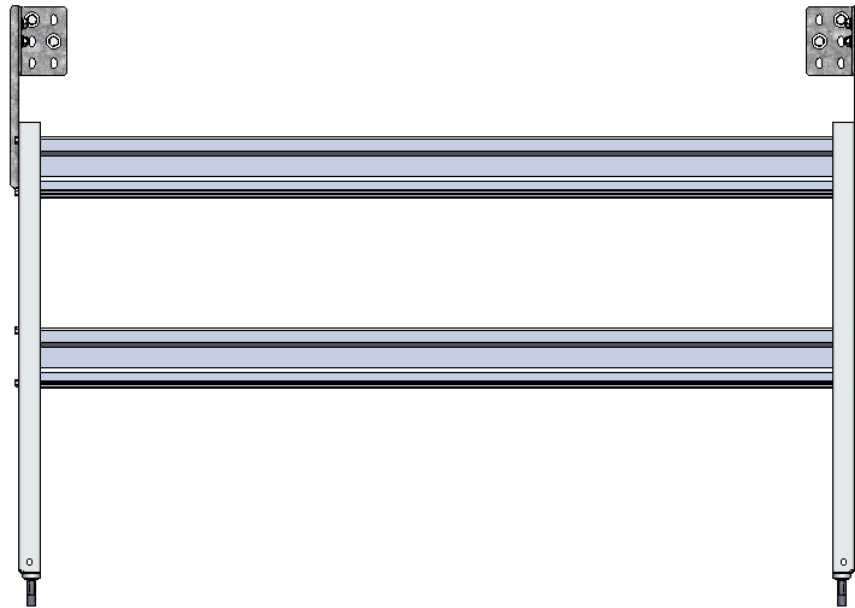





### TOOLS

- Cordless Impact
- 1/2" Socket

### HARDWARE USED

4x

- |   |                                 |
|---|---------------------------------|
|  | #90-212 Hex Bolt 5/16" x 1-1/4" |
|  | #98-122 Lock Washer             |
|  | #98-116 Flat Washer             |
|  | #94-132 5/16" Plusnut           |

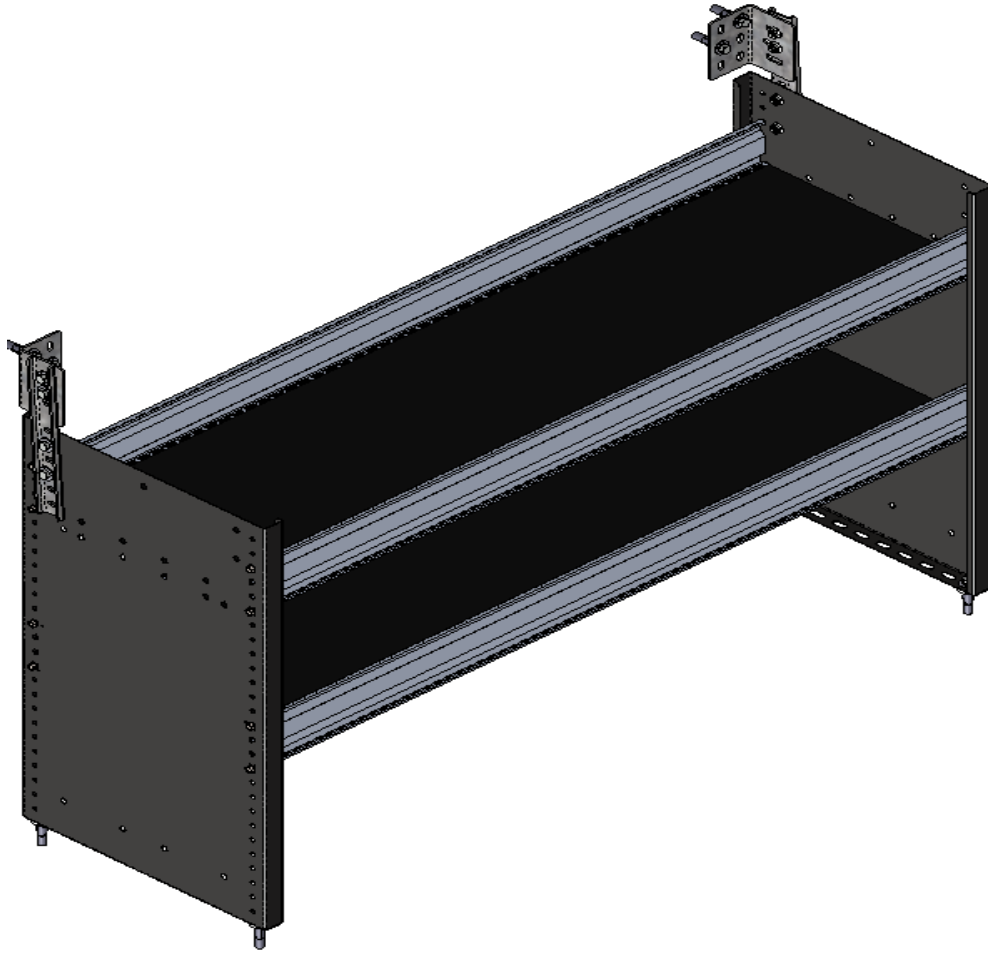

**“You have successfully installed your  
S2-RS48-2**

**Thank you for doing business with us.”**

For any feedback or suggestions you may have, please contact: [cs@rangerdesign.com](mailto:cs@rangerdesign.com)

