

INSTALLATION GUIDE

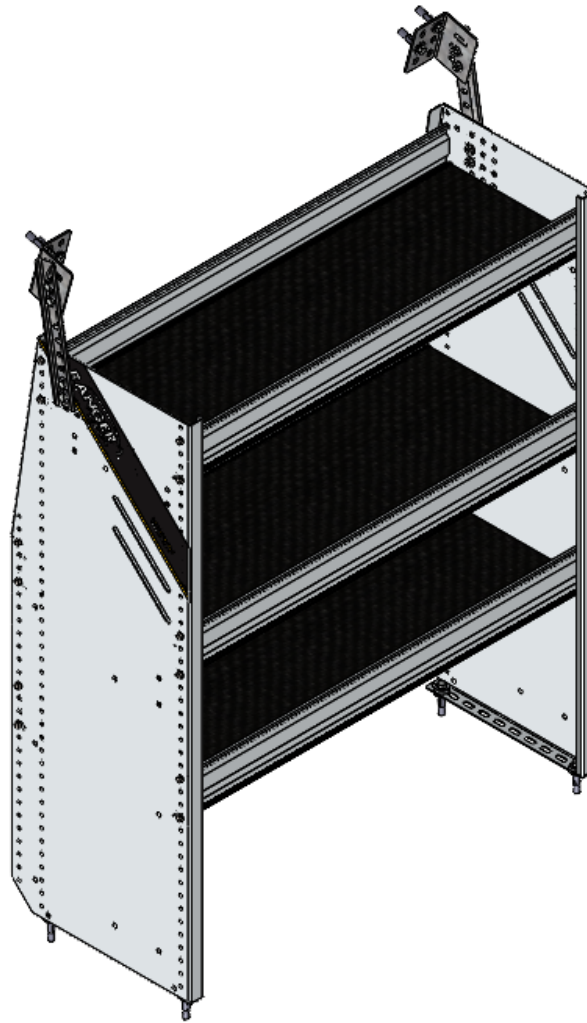

N4-RA36-3C Shelving (ALUMINUM)

Transit Low Roof
Nissan NV Low Roof
GM Savana
Metris
Nissan NV200
City Express



Scan the QR for the latest Install-Guide.





BEFORE YOU BEGIN

READ, UNDERSTAND, AND FOLLOW ALL WARNINGS AND INSTRUCTIONS BEFORE USING THIS PRODUCT. FAILURE TO FOLLOW THESE DIRECTIONS MAY RESULT IN PROPERTY DAMAGE, SERIOUS BODILY INJURY, AND/OR DEATH. RANGER DESIGN IS NOT RESPONSIBLE FOR ANY PROPERTY DAMAGE, PERSONAL INJURY, OR DEATH THAT OCCURRED WHILE USING ANY RANGER DESIGN PRODUCTS.



WARNING

- Failure to use Ranger Design-provided fasteners, brackets, and proper installation guidelines could increase risk of serious personal injury and/or death.
- If drilling is required to complete this installation: improper drilling can cause property damage to vehicles and could lead to electric shock, fire, or even death.
- If drilling is required to complete this installation: Ensure that drilling is only performed on areas of the vehicle allowed by the vehicle's Original Equipment Manufacturer's Body Builders Layout Book (or equivalent document).
- Prior to installation, inspect the vehicle to ensure that installation will not interfere with, or cause obstruction of, any critical components such as electrical wiring, fuel tanks, fuel-cells, locks, latches, etc.
- The installer or manufacturer is responsible for ensuring anchorages are installed onto suitable wall and floor structures; wall and floor strength must meet applicable performance requirements.
- Do not install systems into any weak or unsound materials such as plastics, woods, thin-walled metals, etc. without proper reinforcement.
- Do not install this product where it could interfere with the deployment of airbags. Failure to comply could result in death or serious injury.
- Do not install this product where it could ingress on the Transit Occupant Protection Zone. Failure to comply could result in death or serious injury.
- Incorrect installation could cause water leaks, electric shock or fire.
- Any cargo vehicle with any cargo or equipment should use a certified partition. See Ranger Design website for some partition options. (<https://rangerdesign.com/>)
- Mountings rails are recommended for any attachment to the vehicle walls.
- All items in the cargo area should be properly secured and partition doors closed while the vehicle is in motion.
- Check your vehicle's tare weight and remaining load capacity with all the equipment installed. Never exceed the maximum Gross Vehicle Weight Rating (GVWR), Gross Axle Weight Ratings (GAWRs), or other maximum loads permitted by the vehicle's Original Equipment Manufacturer (OEM) and required by law.
- The heaviest items must be placed towards the bottom of the vehicle, while the lightest ones can be arranged upwards. Vehicle cargo loading weight proportion should follow the following guidelines:

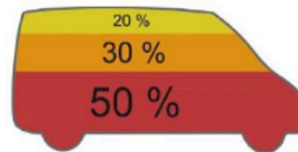

- The final alterer and/ or modifier should review the warning sheet with the customer before the vehicle is released to the customer or for general use. These instructions should remain with the vehicles a all times.
- Any modification or unintended use of this product voids any warranty and could create a hazardous condition.
- Ranger Design provides recommended assembly and installation instructions which should be followed to ensure correct operation. Failure to do so could result in invalidating the product's compliance, warranty and cause injury. Notwithstanding, the final stage vehicle alterer and/or modifier is responsible for the integration, installation, and compliance of the product in its final location to all applicable regulations and standards. Failure to maintain compliance of the vehicle to applicable regulations and standards could be punishable by law. Alterers and/or modifiers should consult with all local authorities prior to commissioning.



CAUTION

- Drilling is required to complete this installation. Before drilling, ensure that you will not hit any critical parts of the vehicle like the gas tank, wiring harness, or hose. Consult the vehicle OEM documentation as necessary. When drilling, use a drill collar to reduce the risk of damage to the vehicle.
- Any materials, padding, or glazing installed in the vehicle must comply with FMVSS/CMVSS 201/205/302, as applicable.
- In the event of a motor vehicle accident or collision where a Ranger system has been installed, especially ones where the vehicle structure is damaged and/or the air bags deploy and/or the vehicle has been towed, the system must be inspected to ensure continued soundness and safety before returning the vehicle to service. Damaged components should be replaced as necessary.
- All system components should be regularly inspected, cleaned, and maintained pursuant to Ranger guidelines.

QUICK START GUIDE

Phase 1 - Assembly

| | |
|--|---|
| <input type="checkbox"/> 1.1 Setup..... | 4 |
| <input type="checkbox"/> 1.2 Shelf Assembly..... | 6 |

Phase 2 - Installation

| | |
|---|----|
| <input type="checkbox"/> 2.1 Bracket installation to shelf..... | 7 |
| <input type="checkbox"/> 3.1 Mark, drill, install plusnuts to vehicle wall..... | 7 |
| <input type="checkbox"/> 4.1 Shelf installation directly to floor | 8 |
| <input type="checkbox"/> 4.2 Shelf installation to 6541 Series..... | 8 |
| <input type="checkbox"/> 4.3 Shelf installation to floor | 9 |
| <input type="checkbox"/> 5.1 Bracket install directly to vehicle | 9 |
| <input type="checkbox"/> 5.2 Bracket install to ranger mounting tracks | 10 |
| <input type="checkbox"/> 5.3 Verify and tighten all fasteners | 10 |

Appendix

| | |
|--|----|
| <input type="checkbox"/> How to use plusnut gun and tool | 11 |
|--|----|

REQUIRED ITEMS

- Cordless Impact
- Cordless Drill
- Tape Measure
- Marker
- 1/2" Socket
- 1/2" Drill Bit w/ Drill Collar (Set at 1/2")
- 3/8" Driver Bit
- Plusnut Tool / Plusnut Gun (5/16")
- Allen Key 8mm
- 7/16" Drill Bit

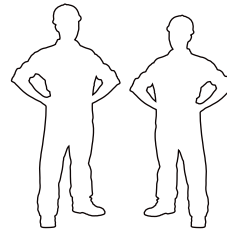

2
PERSONS

PHASE 1 – ASSEMBLY

1.1 SETUP

Unpack components and compare with the bill of materials.

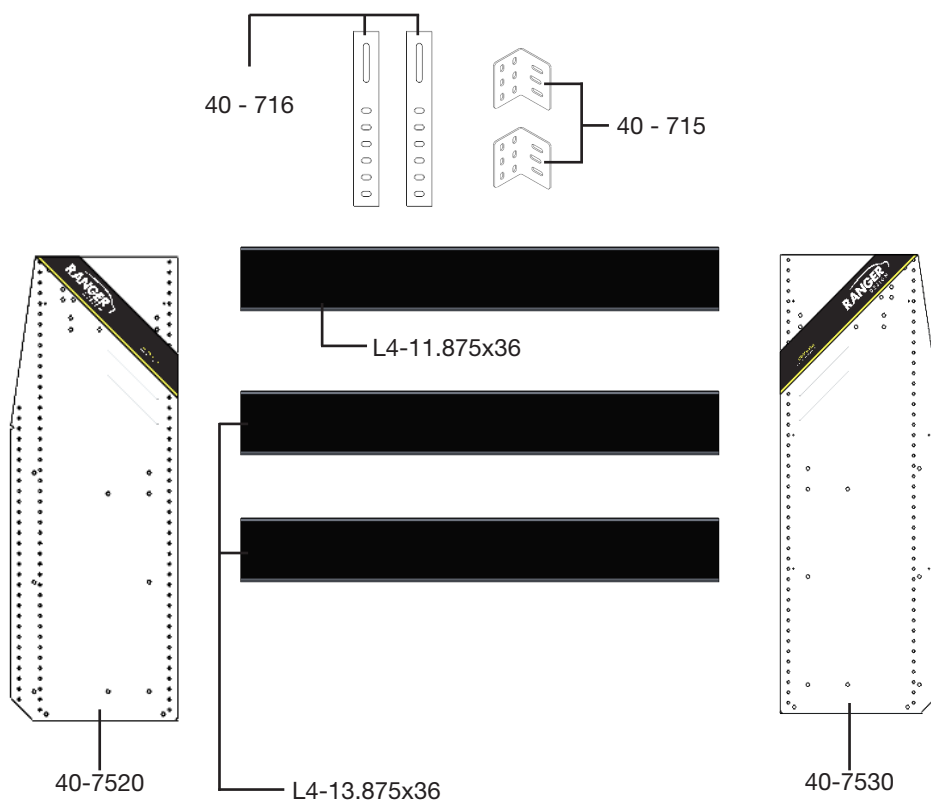

Verify all parts are present.

BILL OF MATERIALS

| Item No. | Description | Qty. |
|--------------|----------------------------------|------|
| 40 - 715 | Bracket Head | 2 |
| 40 - 716 | Bracket Arm | 2 |
| 40 - 7520 | N4 End Panel (Left) | 1 |
| 40 - 7530 | N4 End Panel (Right) | 1 |
| L4-11.875x36 | Shelf Tray, Composite, 12" x 36" | 1 |
| L4-13.875x36 | Shelf Tray, Composite, 14" x 36" | 2 |
| 94 - 4027 | Assembly Fastener Kit | 1 |
| 96 - 4027 | Install Fastener Kit | 1 |

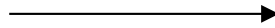

94 - 4027 Fastener Kit



Fastener Assembly

- 8x  # 90-204 Hex Bolt
5/16"-18 x 3/4"
GR-5 ZINC
- 24x  # 92-102 Screw HWH
#14 x 1"
ZINC
- 8x  # 94-116 Serrated Nut
5/16"-18
ZINC
- 8x  # 98-116 Flat Washer
5/16" - 18 x 1"
ZINC

8x

 #90-204 Hex Bolt 5/16" x 3/4"
 #98-116 Flat Washer
 #94-116 Serrated Nut

24x

 #92-102 Screw #14 x 1"



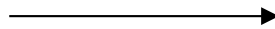

96 - 4027 Fastener Kit







Fastener Assembly

- 4x  # 90-212 Hex Bolt
5/16"-18 x 1-1/4"
GR-5 ZINC
- 4x  # 90-011 Hex Bolt
5/16"-18 x 1-3/4"
GR-5 ZINC
- 8x  # 94-132 Plusnut 5/16"
- 8x  # 98-116 Flat Washer
5/16", O.D. 7/8"
ZINC
- 8x  # 98-122 Lock Washer
5/16"
ZINC
- 4x  # 98-157 Spacer
0.375" ID, x 1.0" OD x 0.25" LONG
NYLON

4x

 #90-212 Hex Bolt 5/16" x 1-1/4"
 #98-122 Lock Washer
 #98-116 Flat Washer
 #94-132 5/16" Plusnut

4x

 #90-011 Hex Bolt 5/16" x 1-3/4"
 #98-122 Lock Washer
 #98-116 Flat Washer
 #98-157 Spacers
 (QTY = GAP BETWEEN FLOOR AND END PANEL)
 #94-132 5/16" Plusnut

PHASE 1 – SHELF ASSEMBLY

1.2 ASSEMBLY

- Attach both panels to the shelf trays.

NOTE: You can adjust the bottom shelf location to maximize or minimize your space over the wheel. If needed, line up the bottom shelf tray bolt with the shelf position guide to ensure clearing all wheel wells.

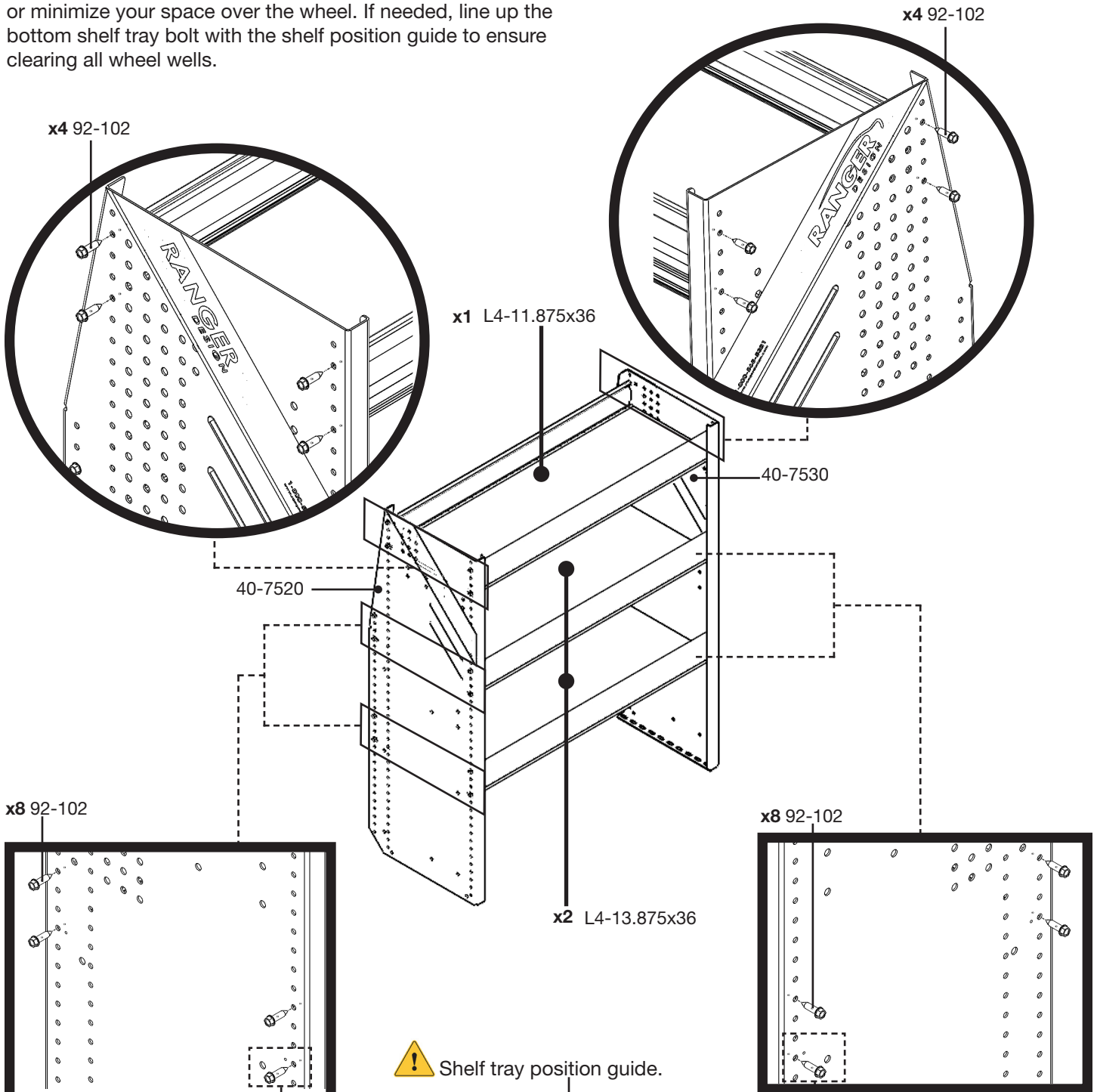

TOOLS

- Cordless Impact
- 3/8" Driver Bit

FASTENERS USED

24 x (12 ft • lbs)

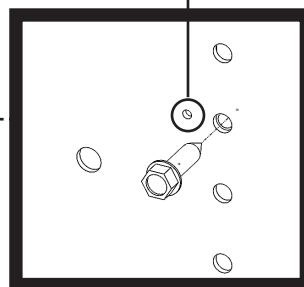
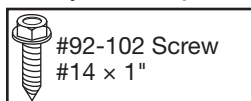

PHASE 2- INSTALLATION

2.1 BRACKET INSTALLATION TO SHELF

- Assemble bracket head and arm.
- Install brackets on to the panel aligning the brackets to the horizontal rim of the vehicle.

NOTE: Brackets can be interchangeable to left or right locations for install flexibility.

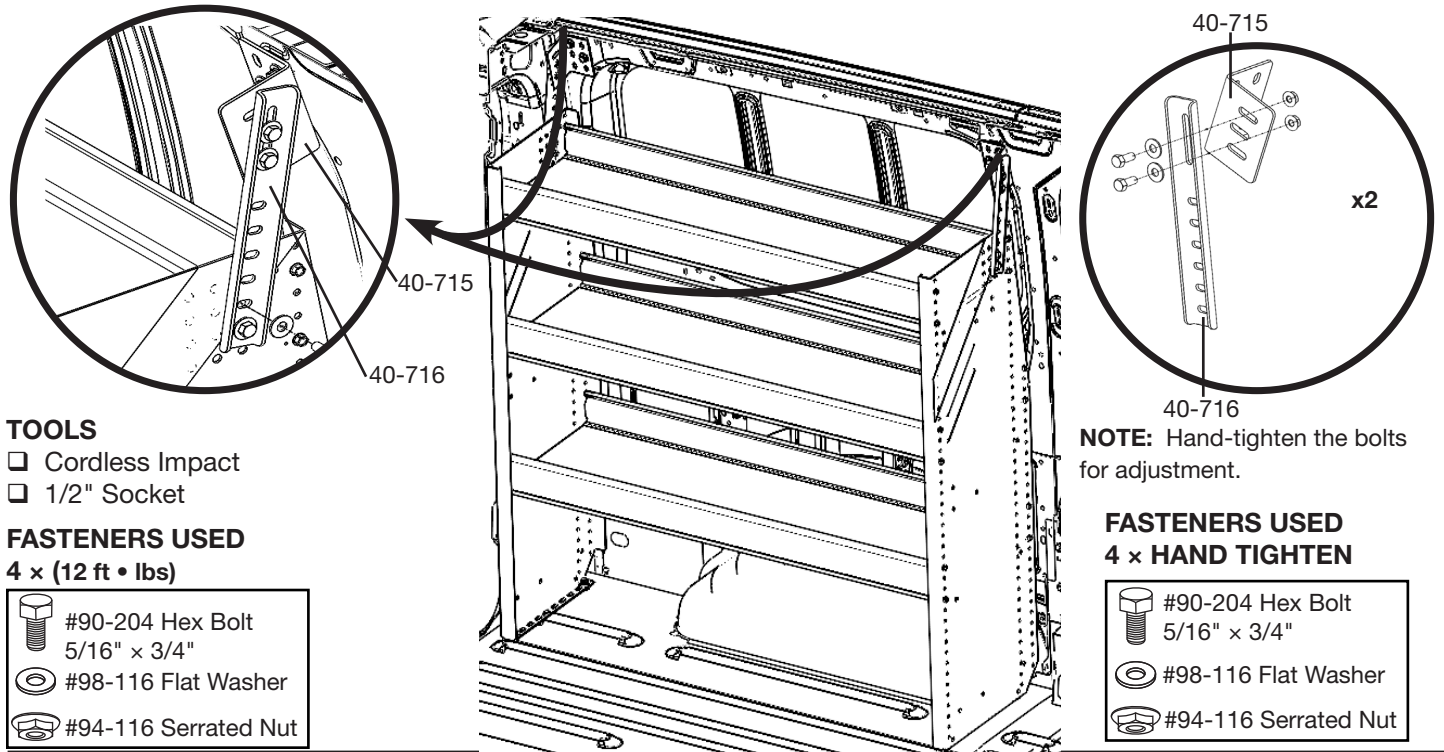

TOOLS

- Cordless Impact
- 1/2" Socket

FASTENERS USED

4 x (12 ft • lbs)

- #90-204 Hex Bolt 5/16" x 3/4"
- #98-116 Flat Washer
- #94-116 Serrated Nut

NOTE: Hand-tighten the bolts for adjustment.

FASTENERS USED 4 x HAND TIGHTEN

- #90-204 Hex Bolt 5/16" x 3/4"
- #98-116 Flat Washer
- #94-116 Serrated Nut

3.1 MARK, DRILL, INSTALL PLUS NUTS TO VEHICLE WALL

- Place the shelf to the preferred location.
- Mark 4 holes using a marker.
- Drill and install plusnuts.

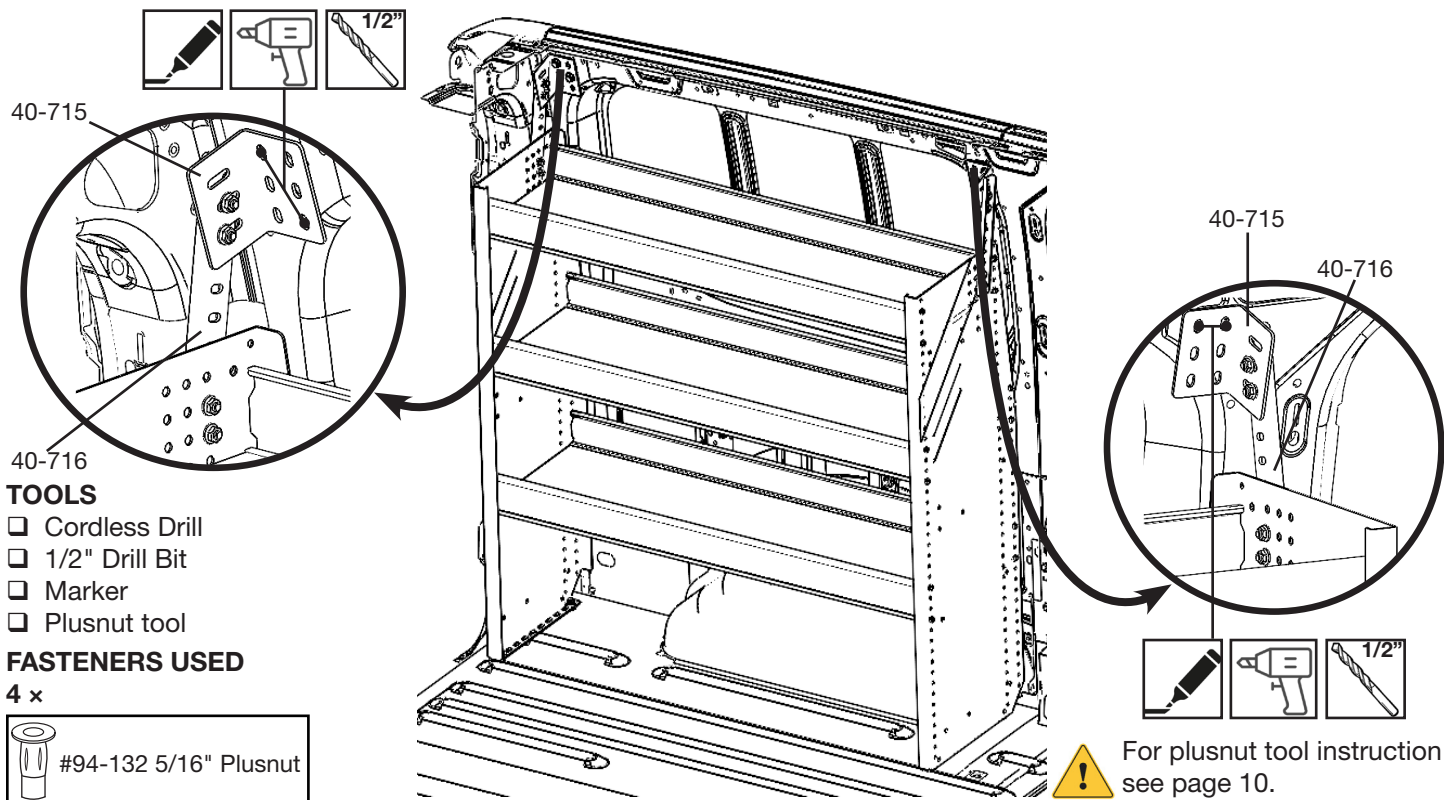

TOOLS

- Cordless Drill
- 1/2" Drill Bit
- Marker
- Plusnut tool

FASTENERS USED

4 x

- #94-132 5/16" Plusnut

For plusnut tool instruction see page 10.

4.1 SHELF INSTALLATION DIRECTLY TO VAN METAL FLOOR

- Using the shelf as template mark plusnut location using maker.
- Drill 4 holes using a 1/2" drill and install plusnuts.
- Align the panel holes to the plusnuts, then install the end panels to the floor using proper hardware provided.

 For plusnut tool instruction see page 10.



TOOLS

- Cordless Drill
- 1/2" Drill Bit
- 1/2" Socket
- Marker
- Plusnut tool

FASTENERS USED

4 x (12 ft • lbs)

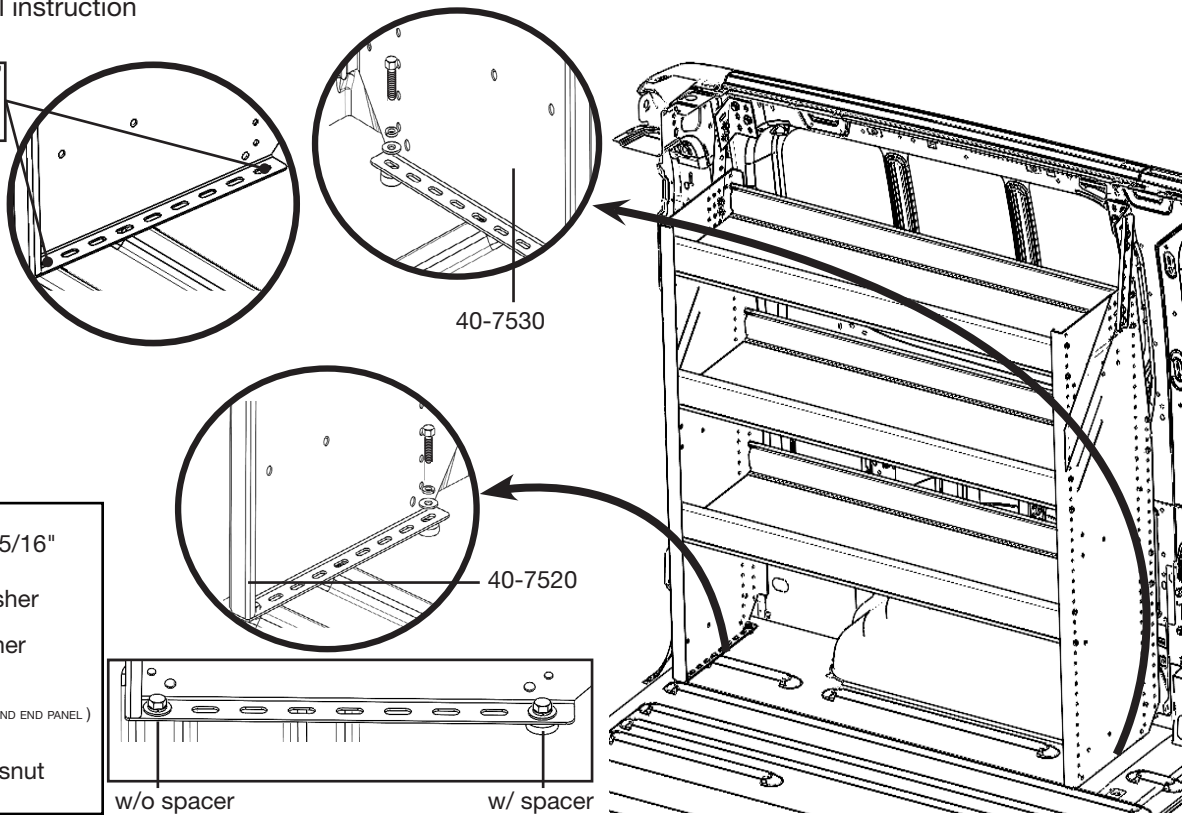
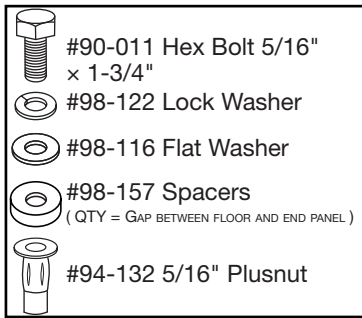

4.2 SHELF INSTALLATION TO 6541 SERIES E-FLOOR

- Using the shelf as template mark wood insert location using marker.
- Drill holes using 7/16" drill bit and install wood inserts using allen key.
- Fasten shelf using hardware provided with the floor.



TOOLS

- Cordless Drill
- 1/2" Socket
- Marker
- 7/16" Drill Bit
- Allen Key 8mm

FASTENERS USED

4 x (12 ft • lbs)

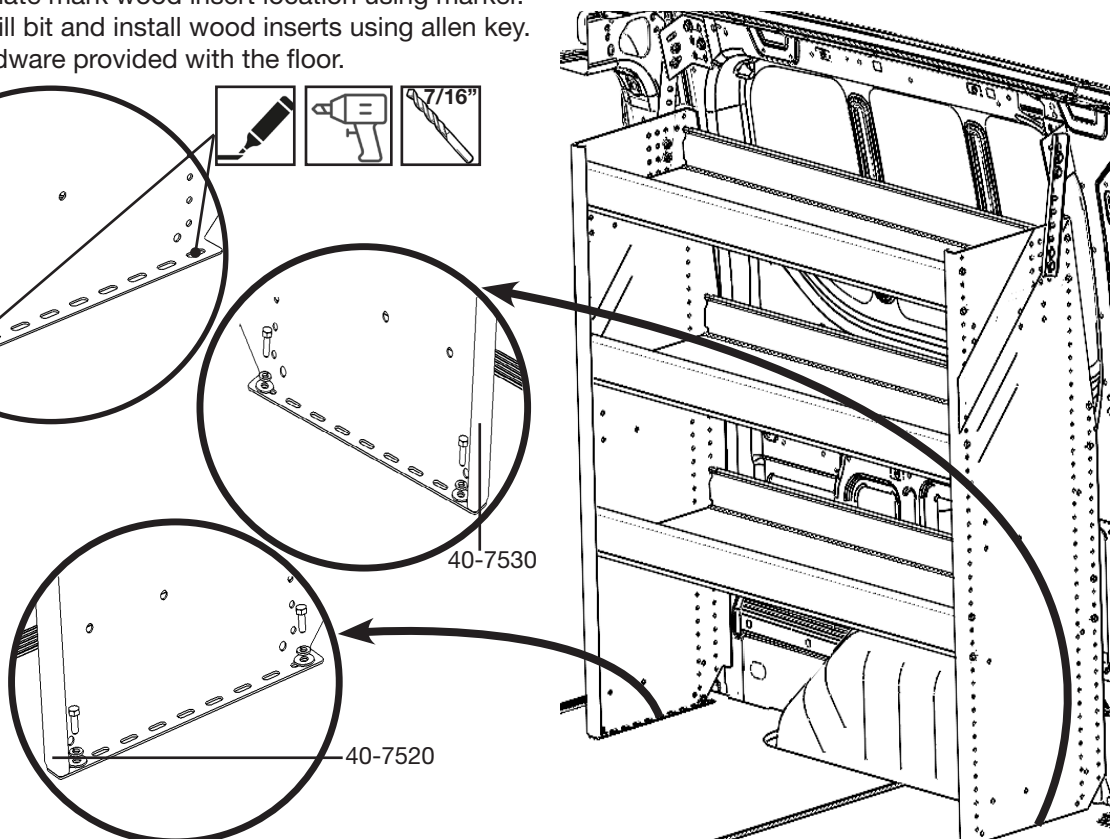
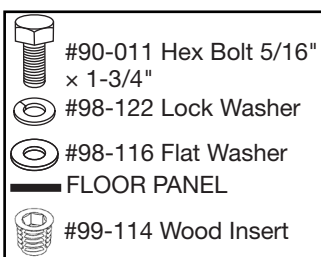

4.3 SHELF INSTALLATION TO 6540 SERIES FLOOR





- Slide 2 carriage bolts into the mounting track.
- Install the front end of the shelf by fastening the carriage bolt on to the panel and secure the shelf using the provided hardware.
- Secure the back end of the shelf by using a tapping screw into each panel on to the floor.

TOOLS

- ☐ Cordless Impact
- ☐ 3/8" Driver Bit
- ☐ 1/2" Socket

FASTENERS USED

2 x (12 ft • lbs)

-  #90-490 Carriage Bolt 5/16" x 1"
-  #98-116 Lock Washer
-  #98-122 Flat Washer
-  #94-104 Hex Nut

FASTENERS USED

2 x (12 ft • lbs)

-  #92-102 Screw 1"

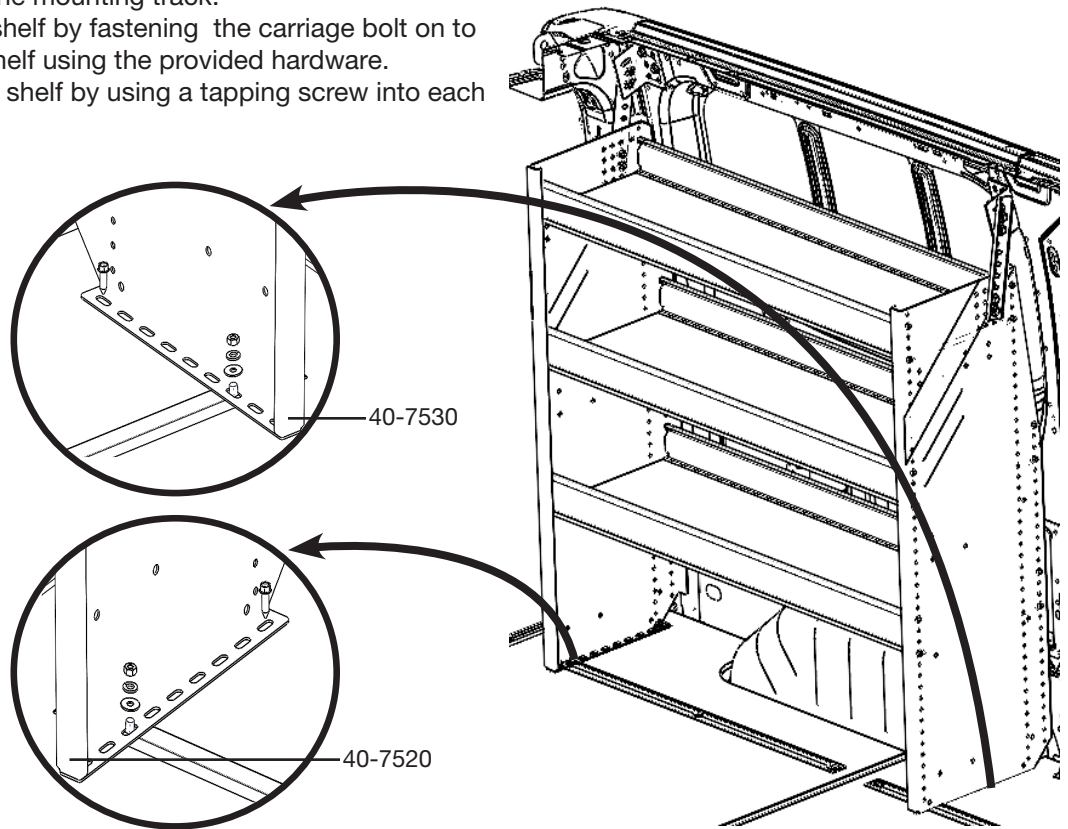

5.1 BRACKET INSTALL DIRECTLY TO VEHICLE

- Using the shelf as template mark plusnut location using maker.
- Drill 4 holes using a 1/2" drill and install plusnuts.
- Align the panel holes to the plusnuts, then install the end panels to the floor using proper hardware provided.

 For plusnut tool instruction see page 10.

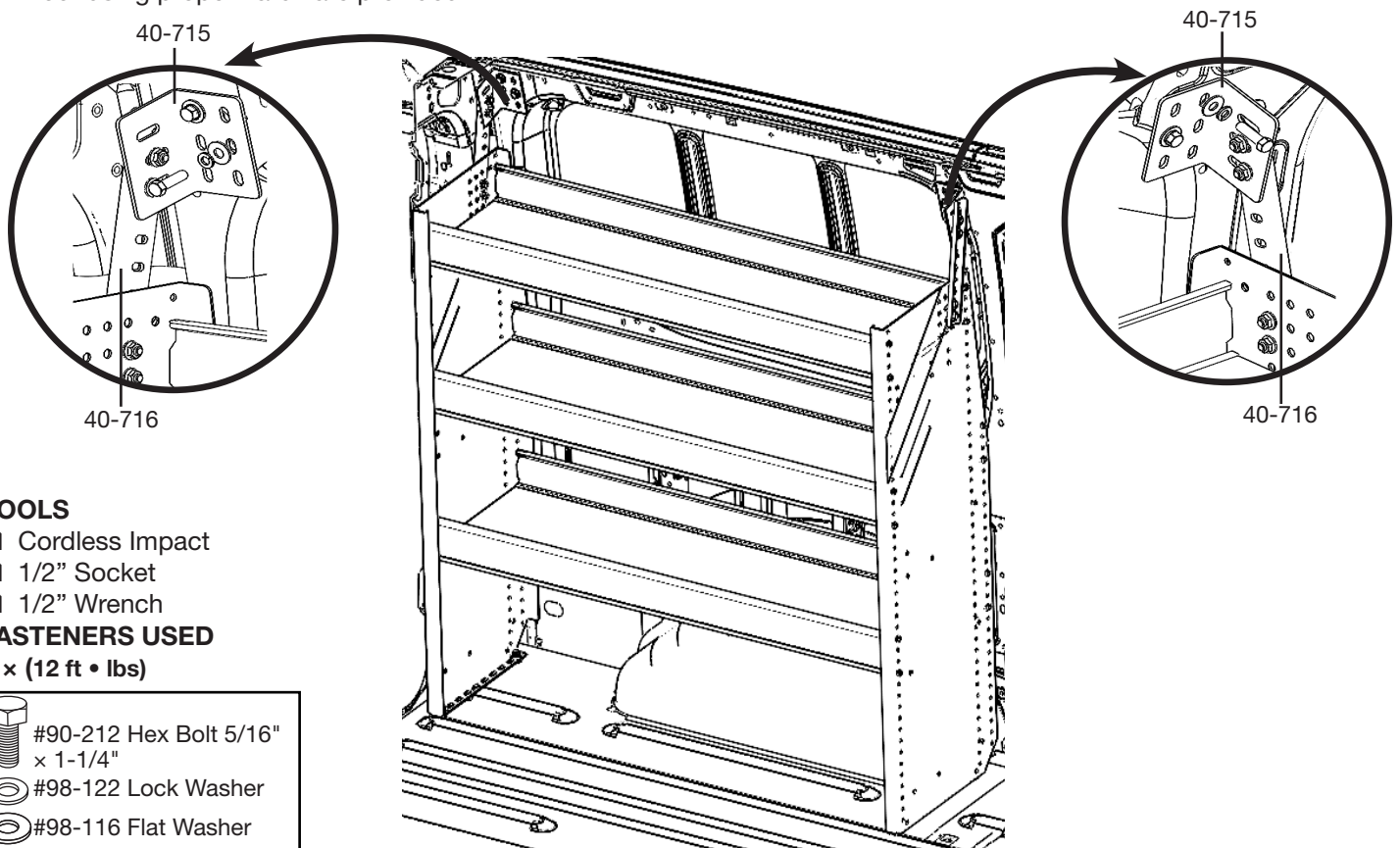
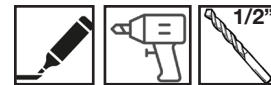

TOOLS

- ☐ Cordless Impact
- ☐ 1/2" Socket
- ☐ 1/2" Wrench

FASTENERS USED

4 x (12 ft • lbs)

-  #90-212 Hex Bolt 5/16" x 1-1/4"
-  #98-122 Lock Washer
-  #98-116 Flat Washer

5.2 BRACKET INSTALL TO RANGER MOUNTING TRACKS

- Align the wall brackets to the wall mounting track kits.
- Install the wall brackets to the wall mounting track kits using channel nuts.







For mounting track install guide, visit website.

TOOLS

- Cordless Impact
- 1/2" Socket

FASTENERS USED

8 x (12 ft • lbs)

| | |
|---|-----------------------------|
|  | #90-208 Hex Bolt 5/16" x 1" |
|  | #98-122 Lock Washer |
|  | #98-116 Flat Washer |
|  | #94-150 Channel Nut |

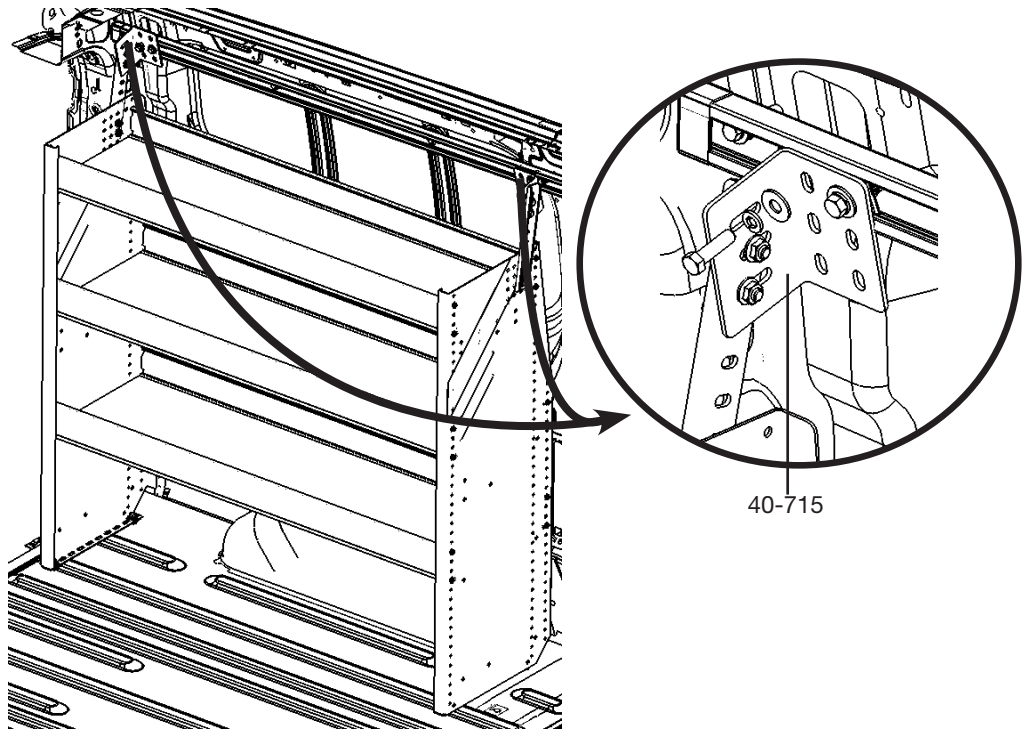

5.3 VERIFY AND TIGHTEN ALL FASTENERS

- Verify and inspect that all fasteners are tightened to recommended torque specification.

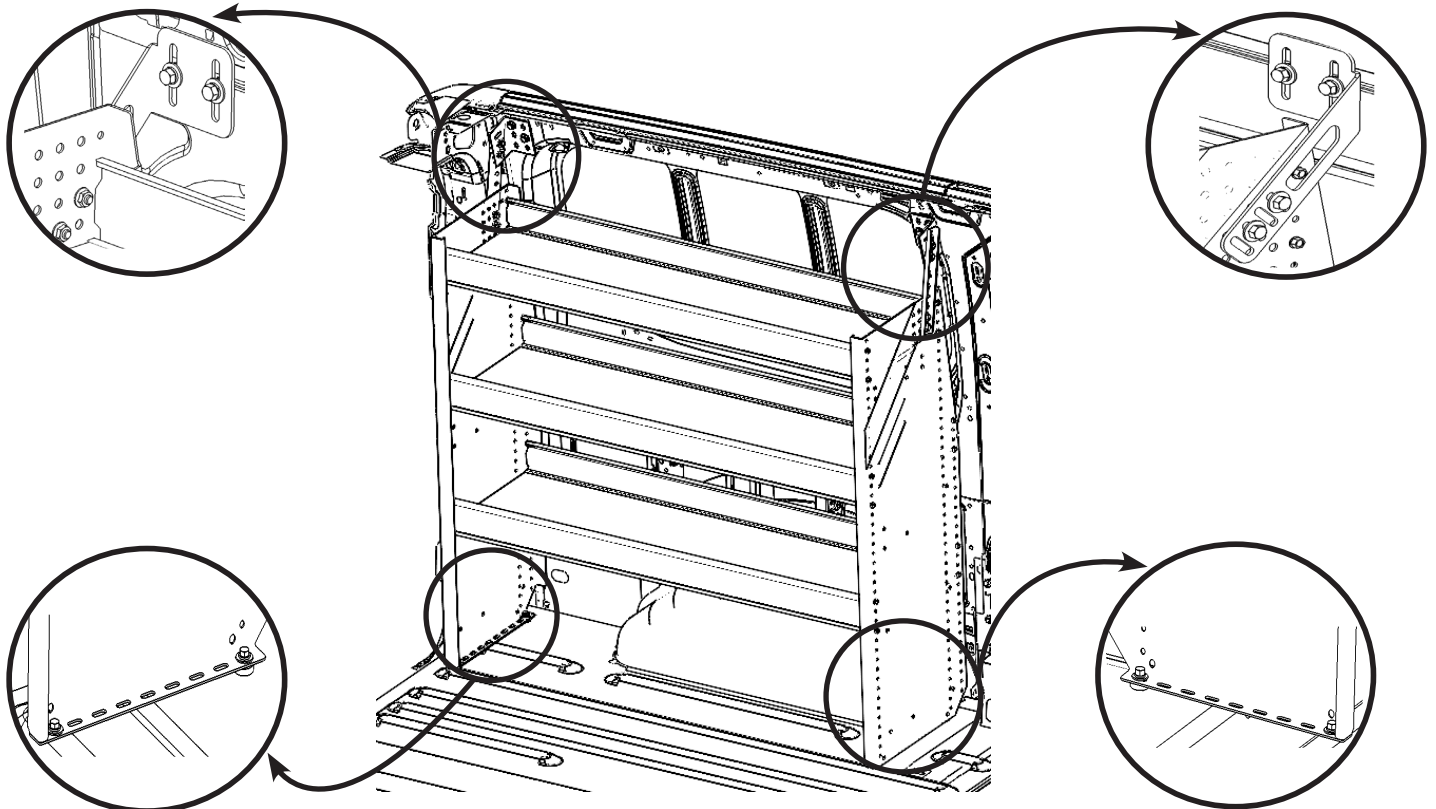

“You have successfully installed your composite aluminum shelving, thank you for doing business with us.”

For any feedback or suggestions, you may have, please contact: cs@rangerdesign.com

APPENDIX:

• USING PLUSNUT GUN

STEP: Put the plusnut on the plusnut gun, then attach the plus nut in the hole by turning the gun forward until the plus nut locks, then remove the gun by turning in reverse.

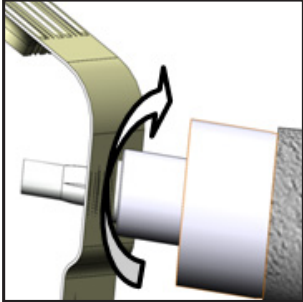

FORWARD

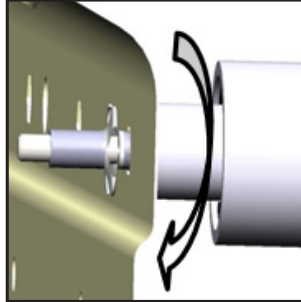

REVERSE

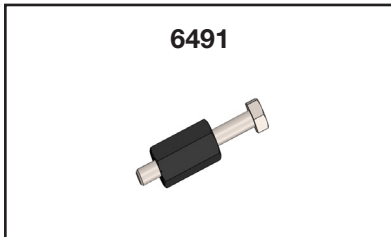

• USING THE 6491 PLUSNUT TOOL

NOTE: The hardware used for the 6491 plusnut tool is not included in the fastener bag. The 6491 plusnut tool can be ordered separately upon demand at no charge.





6491

HARDWARE USED

-  Flat washer 5/16"
-  Flat washer 5/16" BS x 7/8" OD

TOOLS

-  Cordless Impact
-  1/2" Socket
-  9/16" Wrench

STEP 1:

Assemble the 6491 plusnut tool with the hardware needed, plus nut and the 9/16" wrench as shown.



STEP 2:

Attach the plus nut in the hole by turning the bolt forward using an impact with a 1/2" socket until the plusnut locks, then remove the bolt by turning the impact in reverse.

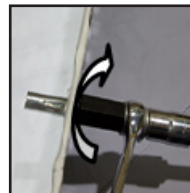

FORWARD



REVERSE