

INSTALLATION GUIDE

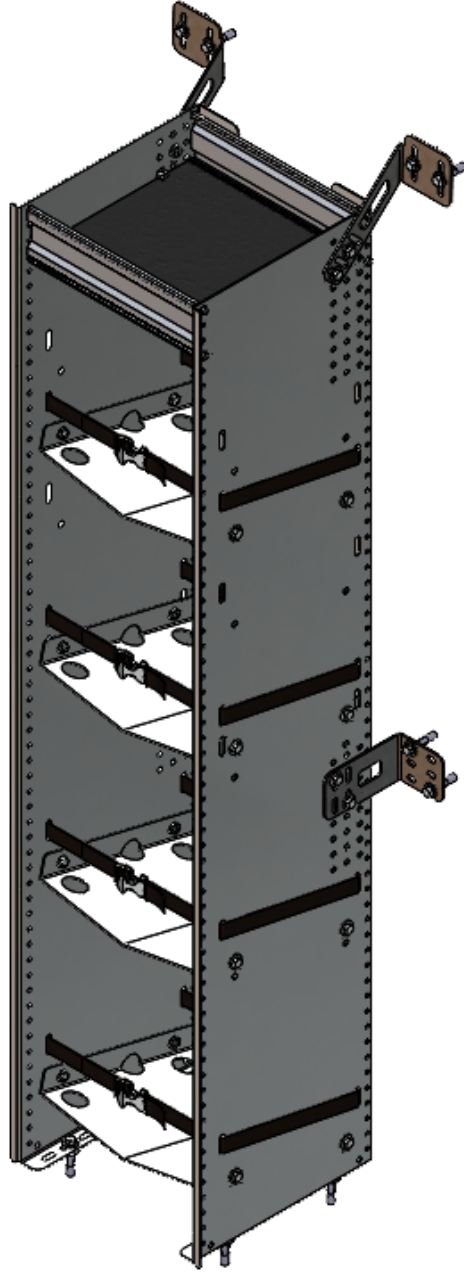

C5-BA13-4 BOTTLE HOLDER



Scan the QR for the latest Install-Guide.





BEFORE YOU BEGIN

READ, UNDERSTAND, AND FOLLOW ALL WARNINGS AND INSTRUCTIONS BEFORE USING THIS PRODUCT. FAILURE TO FOLLOW THESE DIRECTIONS MAY RESULT IN PROPERTY DAMAGE, SERIOUS BODILY INJURY, AND/OR DEATH. RANGER DESIGN IS NOT RESPONSIBLE FOR ANY PROPERTY DAMAGE, PERSONAL INJURY, OR DEATH THAT OCCURRED WHILE USING ANY RANGER DESIGN PRODUCTS.



WARNING

- Failure to use Ranger Design-provided fasteners, brackets, and proper installation guidelines could increase risk of serious personal injury and/or death.
- If drilling is required to complete this installation: improper drilling can cause property damage to vehicles and could lead to electric shock, fire, or even death.
- If drilling is required to complete this installation: Ensure that drilling is only performed on areas of the vehicle allowed by the vehicle's Original Equipment Manufacturer's Body Builders Layout Book (or equivalent document).
- Prior to installation, inspect the vehicle to ensure that installation will not interfere with, or cause obstruction of, any critical components such as electrical wiring, fuel tanks, fuel-cells, locks, latches, etc.
- The installer or manufacturer is responsible for ensuring anchorages are installed onto suitable wall and floor structures; wall and floor strength must meet applicable performance requirements.
- Do not install systems into any weak or unsound materials such as plastics, woods, thin-walled metals, etc. without proper reinforcement.
- Do not install this product where it could interfere with the deployment of airbags. Failure to comply could result in death or serious injury.
- Do not install this product where it could ingress on the Transit Occupant Protection Zone. Failure to comply could result in death or serious injury.
- Incorrect installation could cause water leaks, electric shock or fire.
- Any cargo vehicle with any cargo or equipment should use a certified partition. See Ranger Design website for some partition options. (<https://rangerdesign.com/>)
- Mountings rails are recommended for any attachment to the vehicle walls.
- All items in the cargo area should be properly secured and partition doors closed while the vehicle is in motion.
- Check your vehicle's tare weight and remaining load capacity with all the equipment installed. Never exceed the maximum Gross Vehicle Weight Rating (GVWR), Gross Axle Weight Ratings (GAWRs), or other maximum loads permitted by the vehicle's Original Equipment Manufacturer (OEM) and required by law.
- The heaviest items must be placed towards the bottom of the vehicle, while the lightest ones can be arranged upwards. Vehicle cargo loading weight proportion should follow the following guidelines:

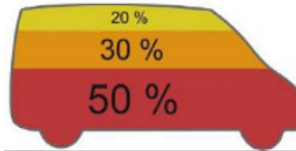

- The final alterer and/ or modifier should review the warning sheet with the customer before the vehicle is released to the customer or for general use. These instructions should remain with the vehicles a all times.
- Any modification or unintended use of this product voids any warranty and could create a hazardous condition.
- Ranger Design provides recommended assembly and installation instructions which should be followed to ensure correct operation. Failure to do so could result in invalidating the product's compliance, warranty and cause injury. Notwithstanding, the final stage vehicle alterer and/or modifier is responsible for the integration, installation, and compliance of the product in its final location to all applicable regulations and standards. Failure to maintain compliance of the vehicle to applicable regulations and standards could be punishable by law. Alterers and/or modifiers should consult with all local authorities prior to commissioning.



CAUTION

- Drilling is required to complete this installation. Before drilling, ensure that you will not hit any critical parts of the vehicle like the gas tank, wiring harness, or hose. Consult the vehicle OEM documentation as necessary. When drilling, use a drill collar to reduce the risk of damage to the vehicle.
- Any materials, padding, or glazing installed in the vehicle must comply with FMVSS/CMVSS 201/205/302, as applicable.
- In the event of a motor vehicle accident or collision where a Ranger system has been installed, especially ones where the vehicle structure is damaged and/or the air bags deploy and/or the vehicle has been towed, the system must be inspected to ensure continued soundness and safety before returning the vehicle to service. Damaged components should be replaced as necessary.
- All system components should be regularly inspected, cleaned, and maintained pursuant to Ranger guidelines.

QUICK START GUIDE

Phase 1 - Assembly

<input type="checkbox"/> 1.1 Setup.....	4
<input type="checkbox"/> 1.2 Bottle holder Assembly.....	7

Phase 2 - Installation

<input type="checkbox"/> 2.1 Attach Wall Brackets To The End Panels.....	8
<input type="checkbox"/> 2.2 Mark Holes For Plus Nuts.....	9
<input type="checkbox"/> 2.3 Attach Plus Nuts.....	10
<input type="checkbox"/> 2.4 Attach Bottle holder To The Floor.....	12
<input type="checkbox"/> 2.5 Attach Wall Brackets.....	14

REQUIRED ITEMS

- Cordless Impact
- Cordless Drill
- Tape Measure
- Marker
- 1/2" Socket
- 1/2" Drill Bit w/ Drill Collar (Set at 1/2")
- 3/8" Driver Bit
- Knife
- Plusnut Tool / Plusnut Gun (5/16")

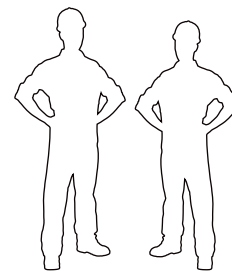

2
PERSONS

PHASE 1 – ASSEMBLY

1.1 SETUP

1.1.1 Unpack components; compare with the bill of materials.

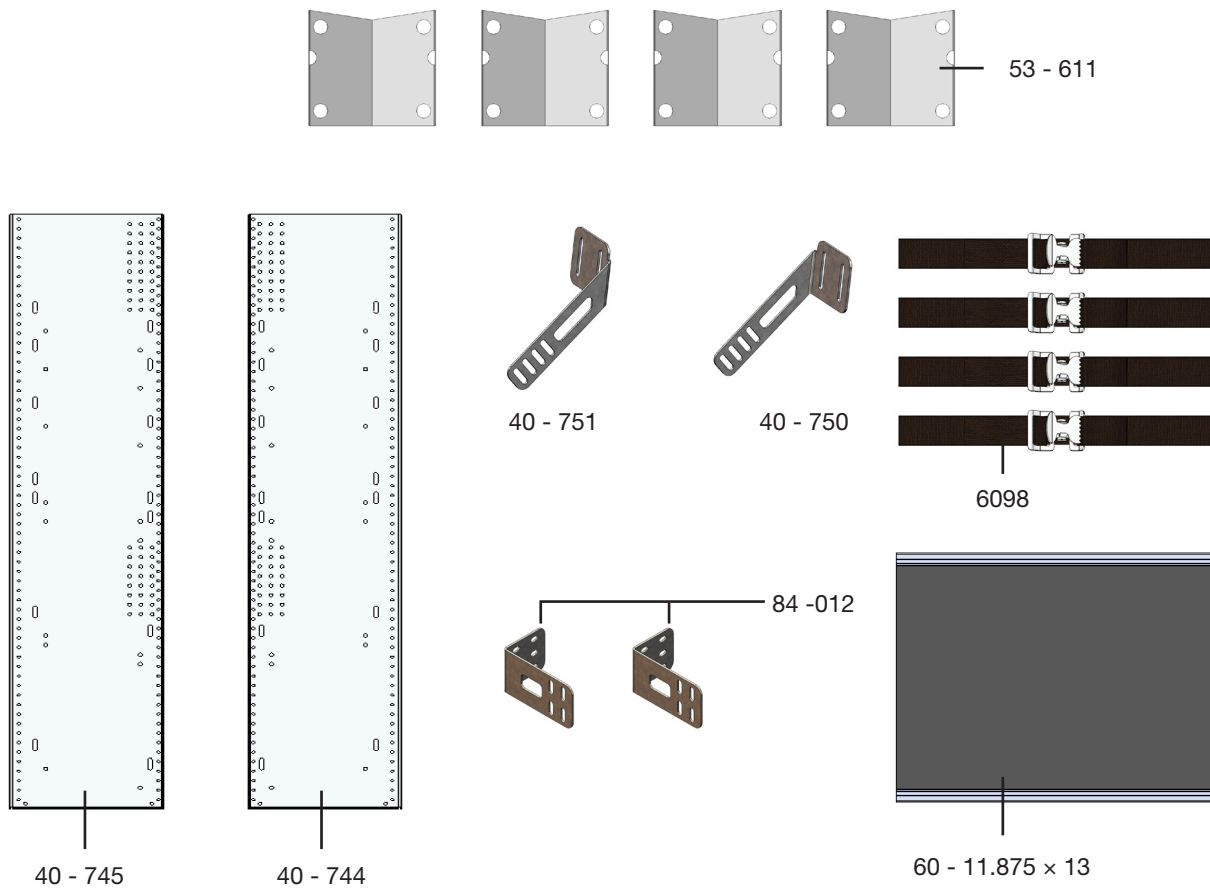

1.1.2 Verify all parts are present.

BILL OF MATERIALS



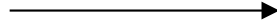

Item No.	Description	Qty.
6098	Strap	4
40 - 750	Bracket, N5 Series, Right	1
40 - 751	Bracket, N5 Series, Left	1
84-012	Foldaway bracket - middle	2
40 - 744	End Panel (Left)	1
40 - 745	End Panel (Right)	1
53 - 611	V Shelf	4
60 - 11.875 x 13	Shelf Tray, Black Plywood	1
94- 5024	Assembly Fastener Kit	1
96 - 5023	Install Fastener Kit	1

1.1.3 Fastener kits.



94 - 5024 Fastener Kit





Fastener Assembly

- 16x**  **# 90-200** Hex Bolt
5/16"-18 x 1/2"
GR-5 ZINC
- 8x**  **# 90-204** Hex Bolt
5/16"-18 x 3/4"
GR-5 ZINC
- 8x**  **# 92-102** Screw HWH
#14 x 1"
ZINC
- 24x**  **# 94-116** Serrated Nut
5/16"-18
ZINC
- 24x**  **# 98-116** Flat Washer
5/16"
ZINC

16x

	#90-200 Hex Bolt 5/16" x 1/2"
	#98-116 Flat Washer
	#94-116 Serrated Nut

8x

	#90-204 Hex Bolt 5/16" x 3/4"
	#98-116 Flat Washer
	#94-116 Serrated Nut

8x

	#92-102 Screw #14 x 1"
--	------------------------

96 - 5023 Fastener Kit

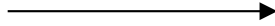

Fastener Assembly

8x  # 90-212 Hex Bolt
5/16"-18 x 1 - 1/4"
GR-5 ZINC

4x  # 90-011 Hex Bolt
5/16"-18 x 1-3/4"
GR-5 ZINC





12x  # 94-132 Plusnut

12x  # 98-116 Flat Washer
5/16", O.D. 7/8"
ZINC





12x  # 98-122 Lock Washer
5/16"
ZINC

4x  # 98-157 Spacer
0.375" ID, x 1.0" OD x 0.25" LONG
NYLON

8x

	#90-212 Hex Bolt 5/16" x 1-1/4"
	#98-122 Lock Washer
	#98-116 Flat Washer
	#94-132 5/16" Plusnut

4x

	#90-011 Hex Bolt 5/16" x 1-3/4"
	#98-122 Lock Washer
	#98-116 Flat Washer
	#98-157 Spacers (QTY = GAP BETWEEN FLOOR AND END PANEL)
	#94-132 5/16" Plusnut

PHASE 1 – ASSEMBLY

1.2 BOTTLE HOLDER ASSEMBLY

1.2.1 Attach both panels to the shelf trays.

IMPORTANT: Assemble the cabinet on a protected clean surface to avoid scratching.

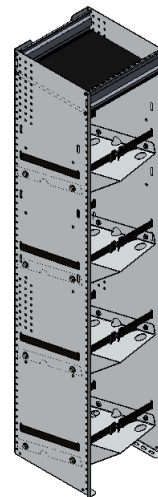
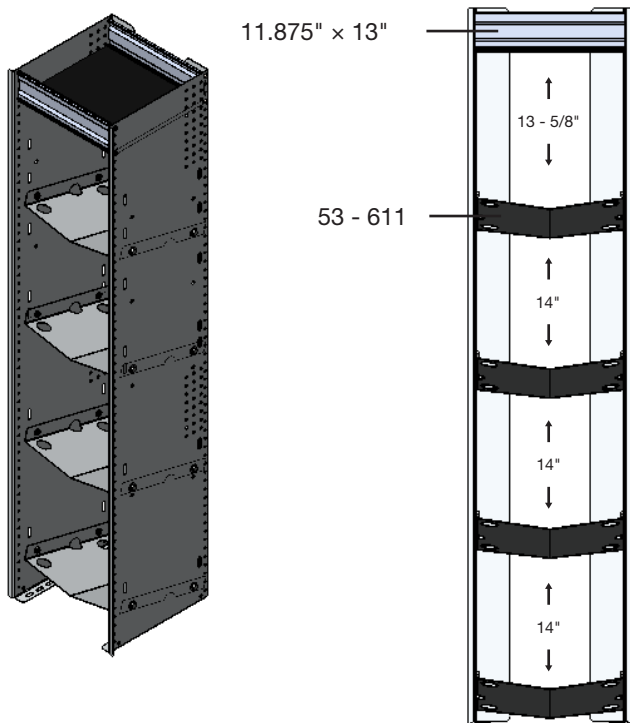

Attach the straps to the end panels.

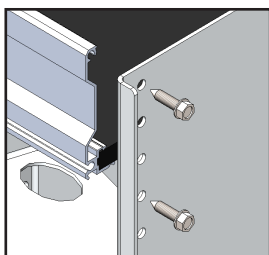
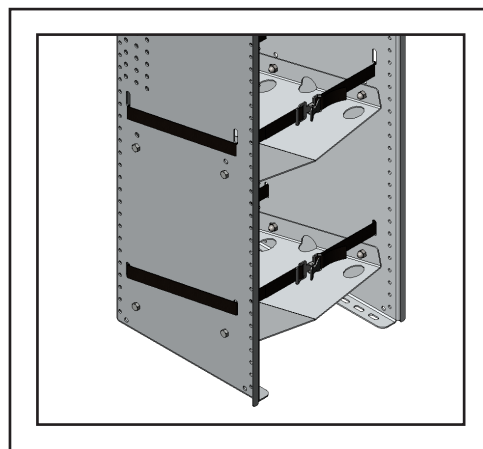

TOOLS

- Cordless Impact
- 3/8" Driver Bit

HARDWARE USED

8x 94 - 5024



#92-102 Screw #14 x 1"

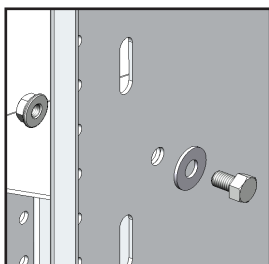

TOOLS

- Cordless Impact
- 1/2" Socket

HARDWARE USED

16x 94 - 5024



#90-200 Hex Bolt 5/16" x 1/2"



#98-116 Flat Washer



#94-116 Serrated Nut

PHASE 2 – INSTALLATION

2.1 ATTACH WALL BRACKETS TO THE END PANELS

- 2.1.1 • Place the assembled bottle holder into the vehicle, at the desired location.
• Attach the brackets to the panels aligning the bracket to the horizontal rim of the vehicle.

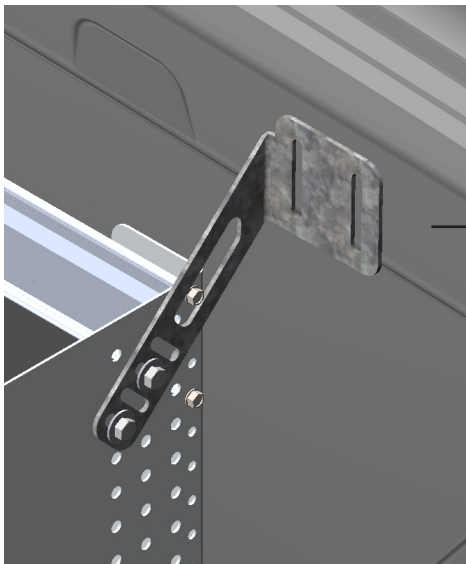
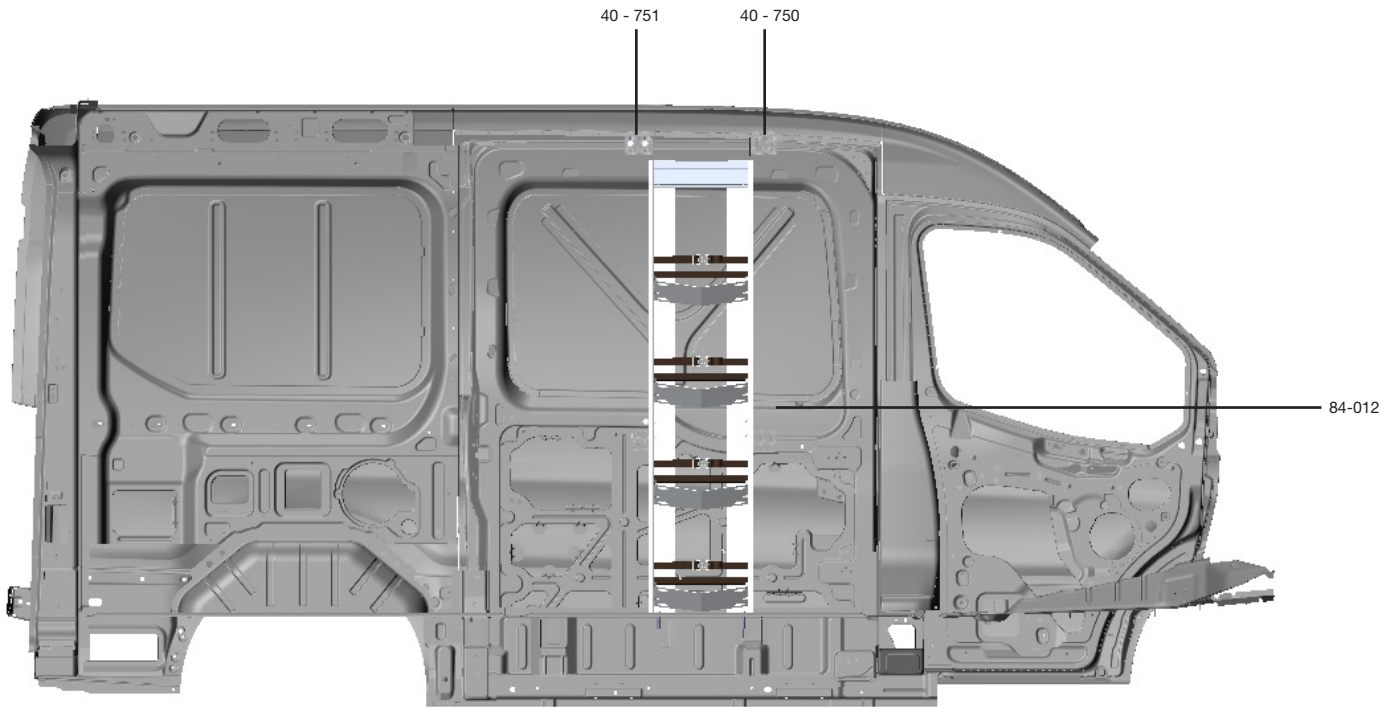



TOOLS

- ☐ Cordless Impact
- ☐ 1/2" Socket

HARDWARE USED

8x HAND-TIGHTEN THE BOLTS

- | | |
|---|-------------------------------|
|  | #90-204 Hex Bolt 5/16" x 3/4" |
|  | #98-116 Flat Washer |
|  | #94-116 Serrated Nut |



PHASE 2 – INSTALLATION

2.2 MARK HOLES FOR PLUS NUTS

2.2.1 After attaching the brackets, mark the plus nut location on the vehicle rim.

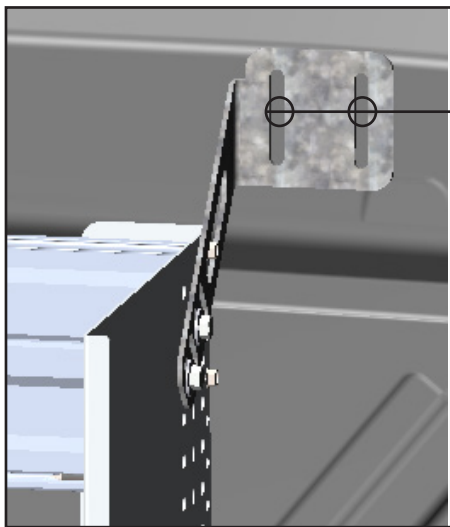
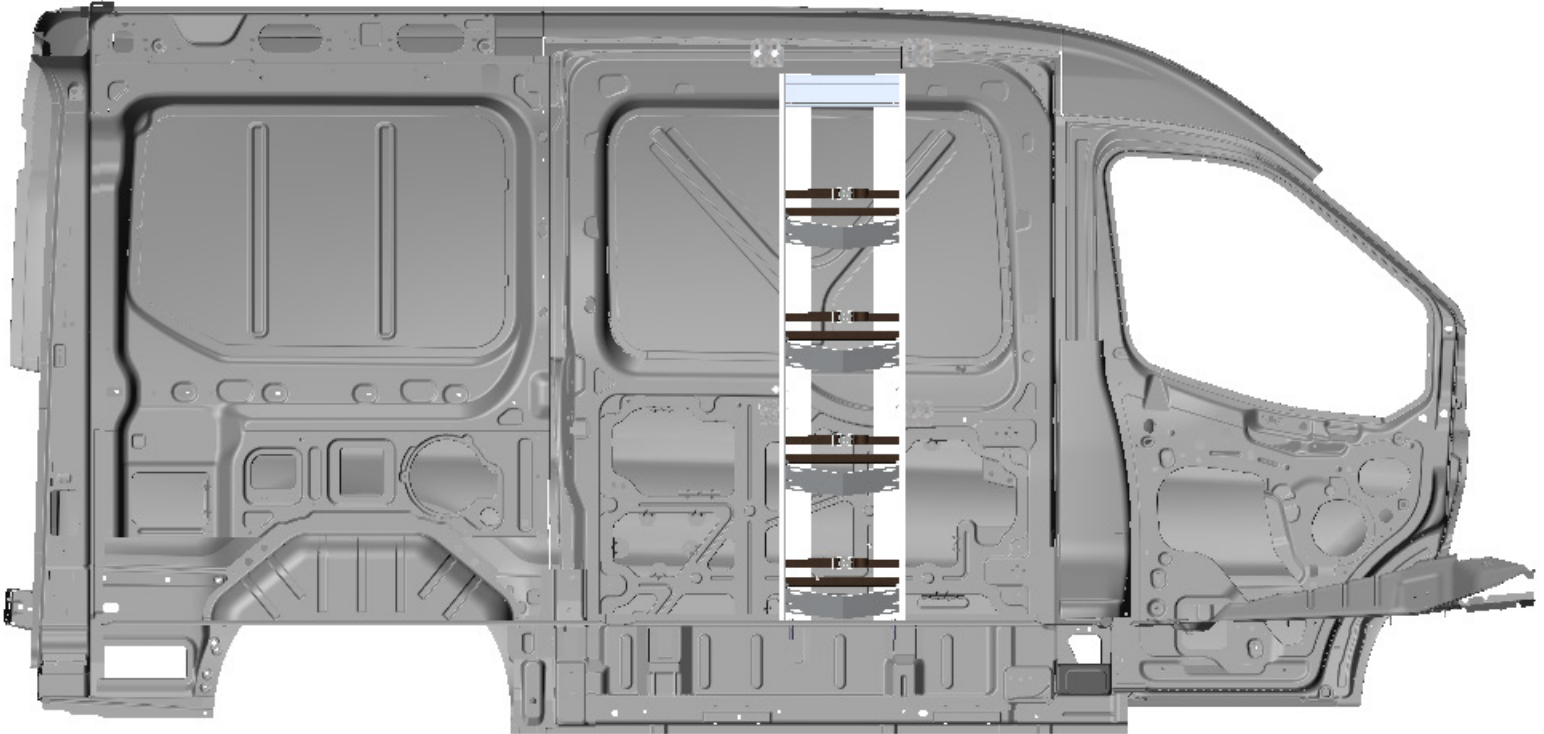

Mark 8 holes of the brackets on the vehicle as shown on the image.

NOTE: If you are using Ranger wall kits, please go to **PAGE 14**.

TOOLS
□ Marker

MARK

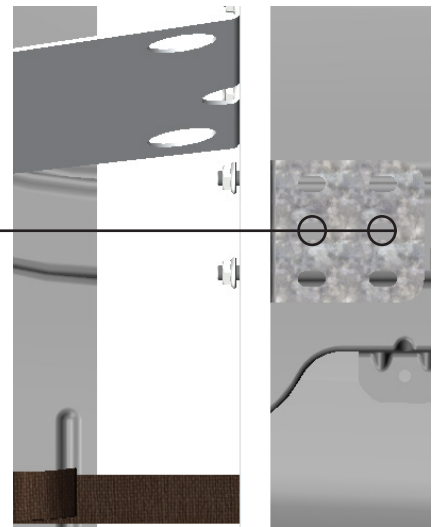

PHASE 2 – INSTALLATION

2.3 ATTACH PLUS NUTS

- 2.3.1**
- Move the assembled bottle holder on the side.
 - Drill all the marks using 1/2" drill bit w/ drill collar, then insert the plus nuts.

NOTE: Use 1/2" drill bit with drill collar to stop drill at 1/2" depth.

WARNING: Before drilling, ensure that you will not hit any critical parts of the vehicle such as the **Gas tank**, **Wiring Harness** and **Hose**.

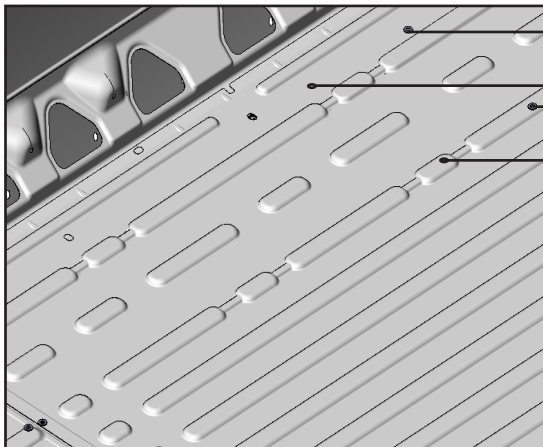
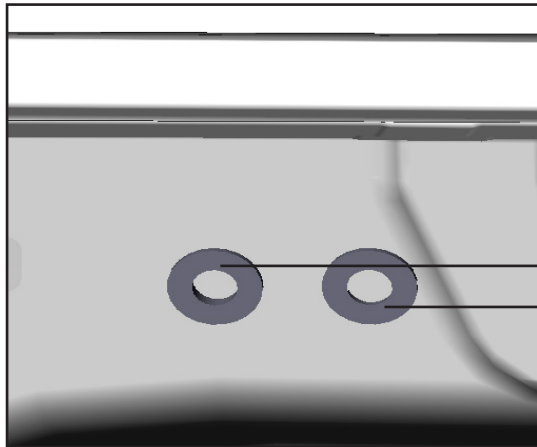
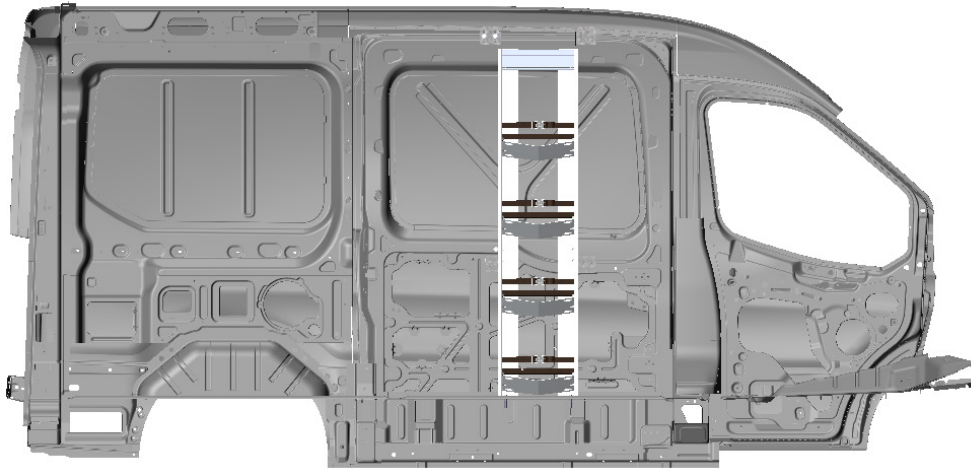

PLUSNUT

Drill all the marks then, attach plus nuts to the holes.

TOOLS

- Cordless Drill
- 1/2" Drill Bit w/ Drill Collar (Set at 1/2")
- Plus Nut Tool (5/16")

HARDWARE USED

12x



#94-132 Plus Nut



DRILL COLLAR
(SET AT 1/2")

2.3.2 How to attach plus nut.

• USING PLUSNUT GUN

STEP: Put the plusnut on the plusnut gun, then attach the plus nut in the hole by turning the gun forward until the plus nut locks, then remove the gun by turning in reverse.

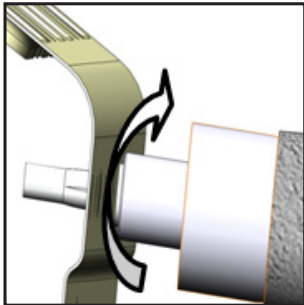

FORWARD

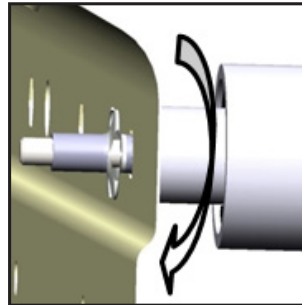

REVERSE

• USING THE 6491 PLUSNUT TOOL

NOTE: The hardware used for the 6490 plusnut tool is not included in the fastener bag. The 6490 plusnut tool can be ordered separately upon demand at no charge.

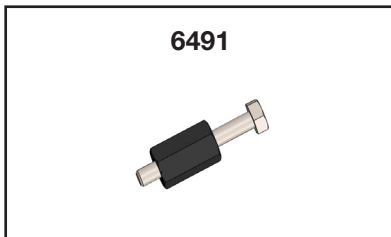

6491

HARDWARE USED

-  Flat washer 5/16"
-  Flat washer 5/16" BS x 7/8" OD

TOOLS

- Cordless Impact
- 1/2" Socket
- 9/16" Wrench

STEP 1:

Assemble the 6491 plusnut tool with the hardware needed, plus nut and the 9/16" wrench as shown.



STEP 2:

Attach the plus nut in the hole by turning the bolt forward using an impact with a 1/2" socket until the plusnut locks, then remove the bolt by turning the impact in reverse.

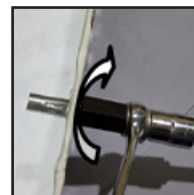

FORWARD



REVERSE

PHASE 2 – INSTALLATION

2.4 ATTACH END PANEL TO THE FLOOR

WITHOUT RANGER FLOOR

2.4.1 Place the assembled bottle holder back into the vehicle and fasten to the plus nut.

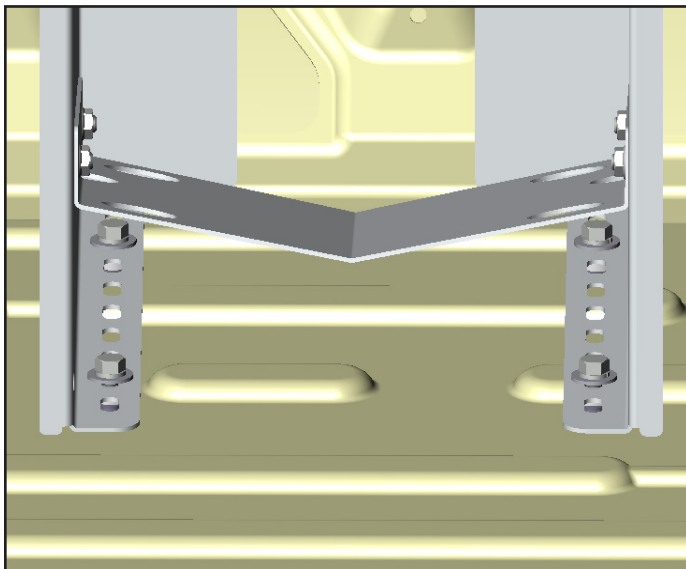
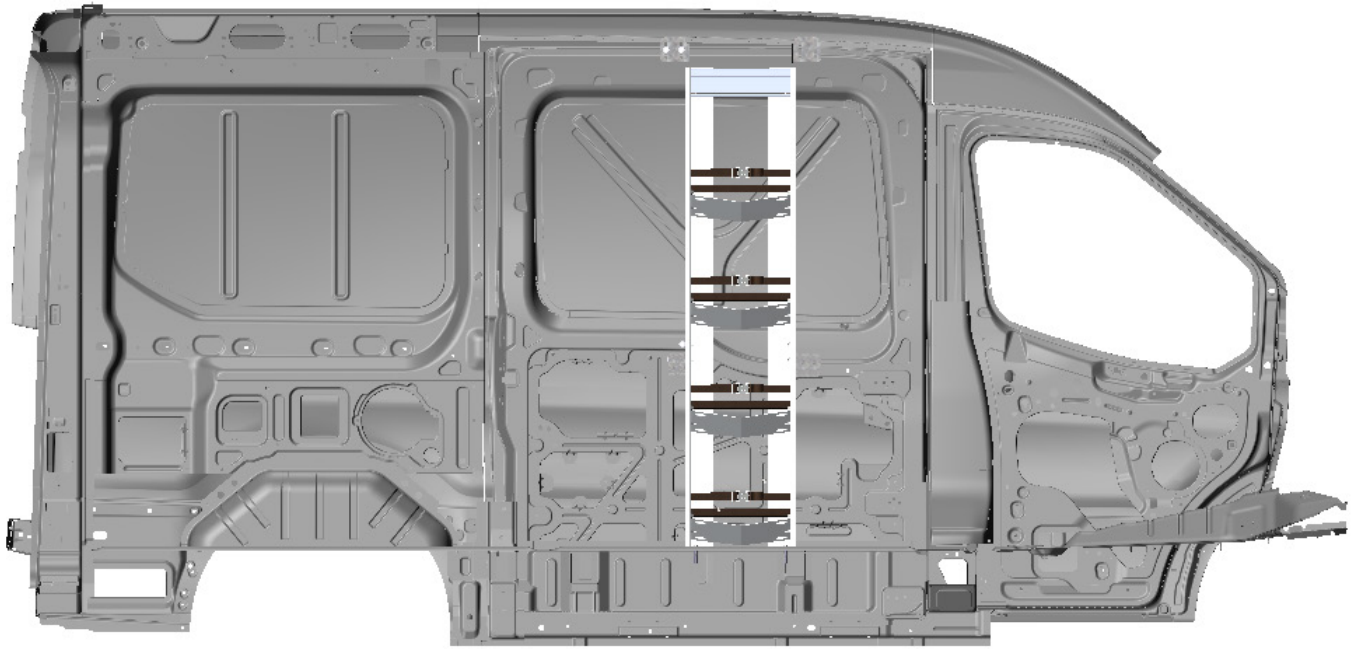

TOOLS

- Cordless Impact
- 1/2" Socket

HARDWARE USED

4x



#90-011 Hex Bolt 5/16" x 1-3/4"

#98-122 Lock Washer

#98-116 Flat Washer

#98-157 Spacers

(QTY = GAP BETWEEN FLOOR AND END PANEL)

#94-132 5/16" Plusnut

MOST VEHICLE USE 1 SPACER WHEN NOT OVER RIBS

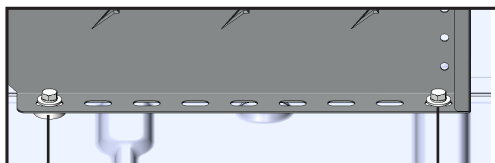

W/ Spacer

W/O Spacer

WITH RANGER FLOOR

- 2.4.2**
- Lift the bottle holder unit inside the van, then put it in place.
 - Install the bottle holder unit to the floor mounting track by sliding bolts in the mounting tracks, and putting screw in the last rear slot of the end panels of the shelving unit.

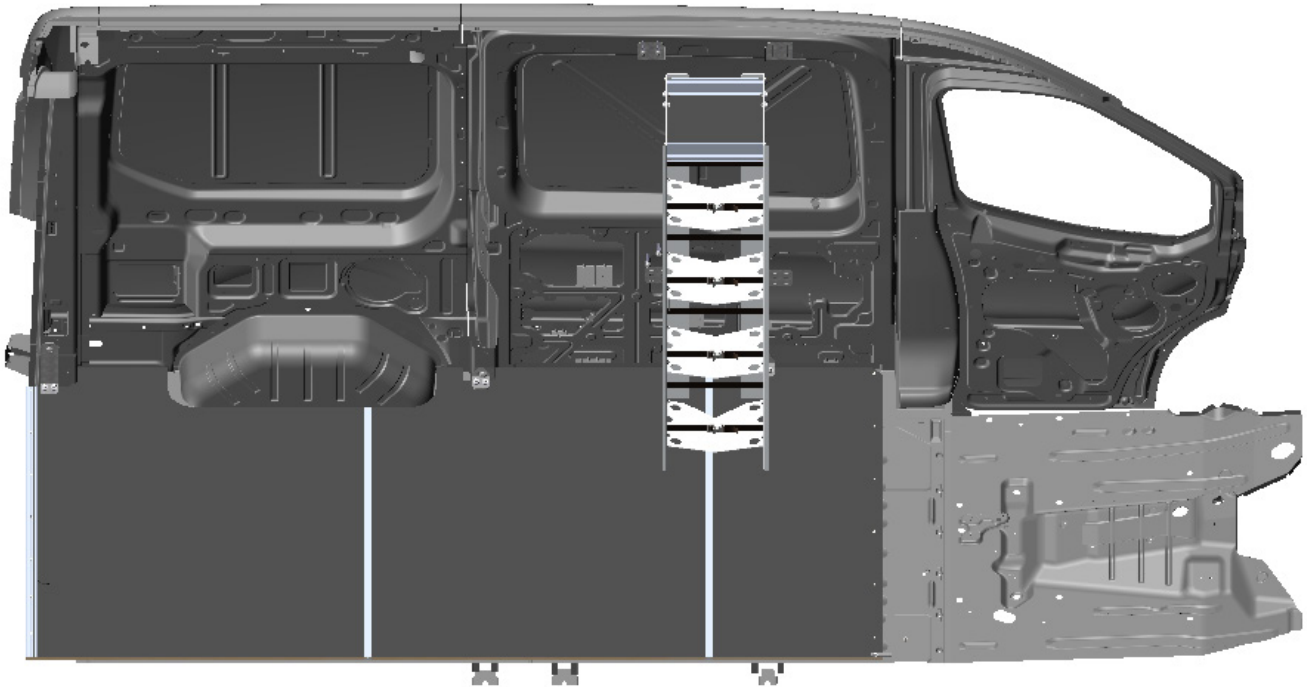

STANDARD FLOOR

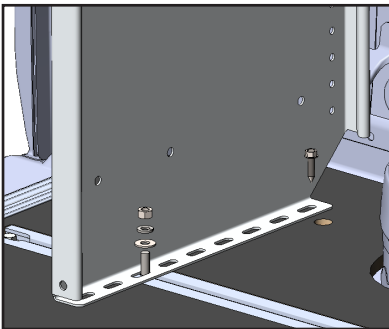

TOOLS

- Cordless Impact
- 3/8" Driver Bit
- 1/2" Socket

HARDWARE USED

2x FLOOR FASTENER KIT



#92-102 Screw 1"

HARDWARE USED

2x FLOOR FASTENER KIT



#90-490 Carriage Bolt 5/16" x 1"



#98-122 Flat Washer



#98-116 Lock Washer



#94-104 Hex Nut

E-FLOOR

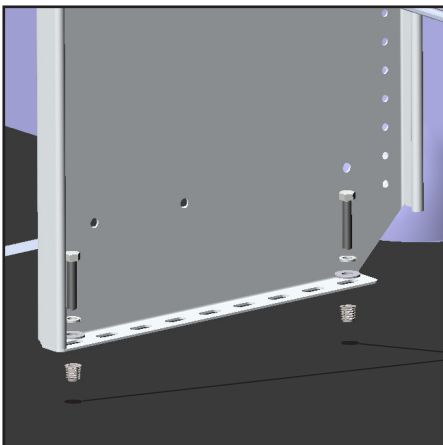

7/16 drill hole

TOOLS

- Marker
- 7/16" Drill Bit
- 1/2" Socket
- Drill Collar

HARDWARE USED

4x HAND-TIGHTEN THE BOLTS



#90-204 Hex Bolt 5/16" x 3/4"



#98-116 Lock Washer



#98-116 Flat Washer



#99-114 Zinc Alloy Tapping Inserts for Softwood

PHASE 2 – INSTALLATION

2.5 ATTACH WALL BRACKETS

WITHOUT RANGER WALL KITS

2.5.1 First align and fasten the wall brackets to the plus nuts, then align and fasten the wall brackets to the end panels.

IMPORTANT: After installation is completed, ensure all bolts are tightened.

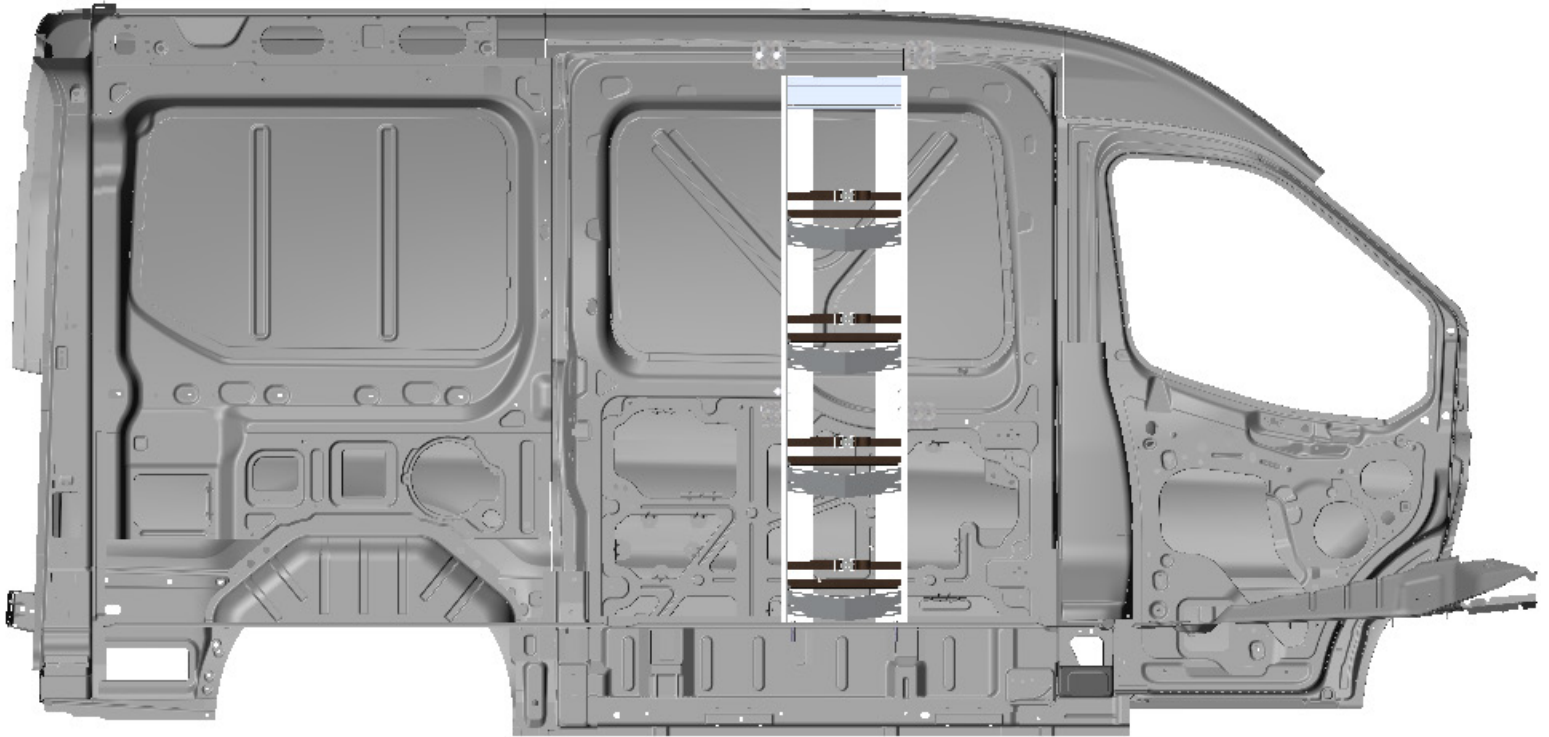

TOOLS

- Cordless Impact
- 1/2" Socket

HARDWARE USED

8x



#90-212 Hex Bolt 5/16" x 1-1/4"

#98-122 Lock Washer

#98-116 Flat Washer

#94-132 5/16" Plusnut

WITH RANGER WALL KITS

2.5.2 First align the wall brackets to the wall mounting track kits, then install the wall brackets to the wall mounting track kits using channel nuts.

IMPORTANT: First tighten the bolts that secure the wall bracket to the wall or wall kits, and then tighten the bolts that secure wall bracket to the end panels. After installation is completed, ensure all bolts are properly tightened.

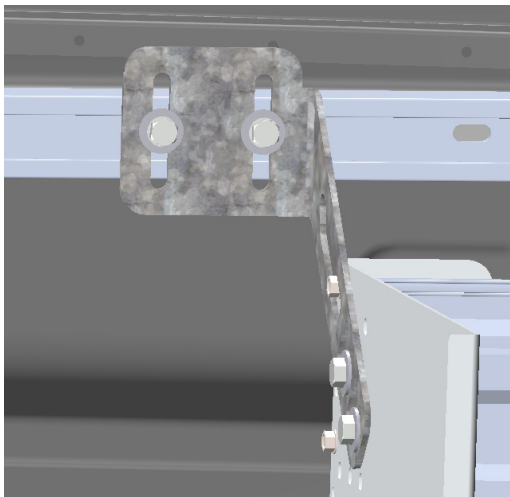
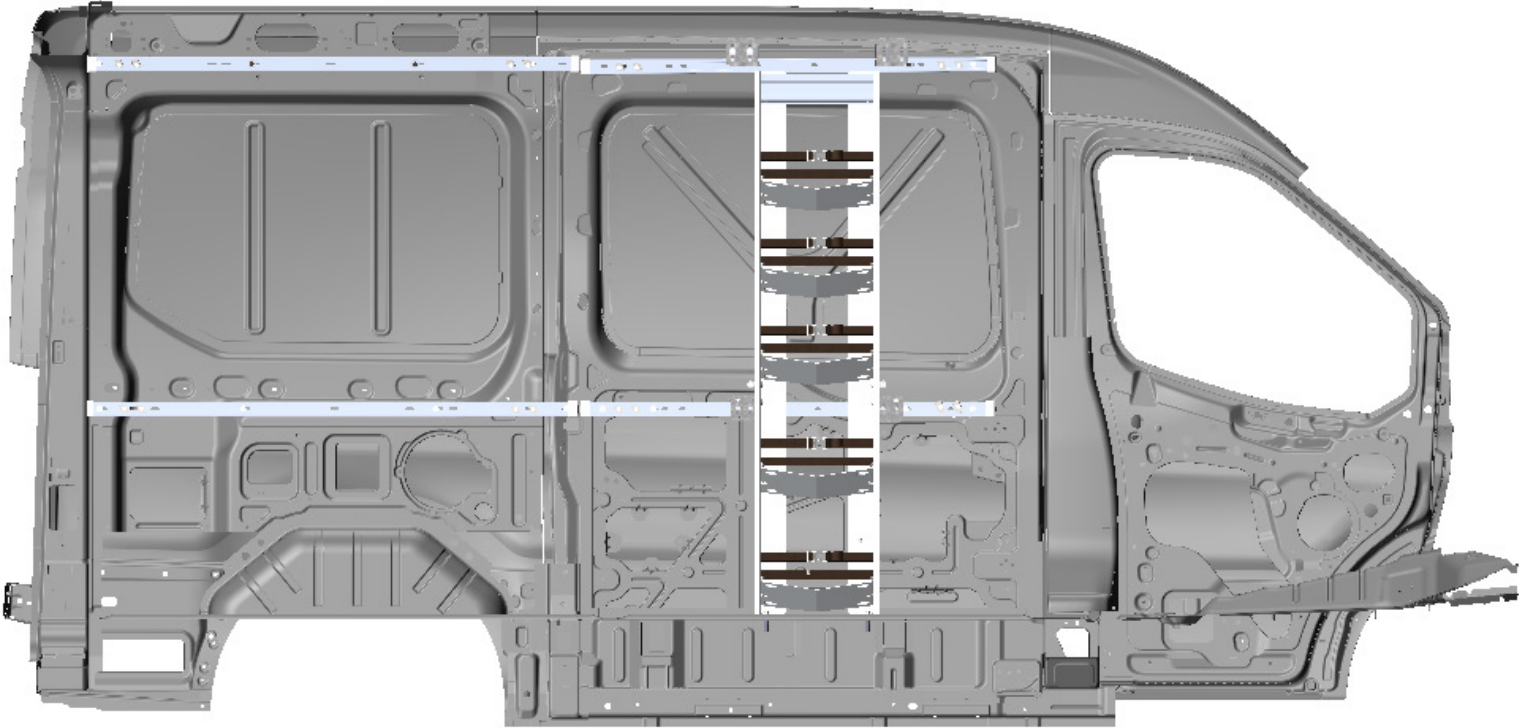

TOOLS

- Cordless Impact
- 1/2" Socket

FASTENERS USED

8x WALL KITS FASTENER KIT

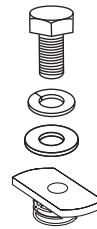

#90-208 Hex Bolt 5/16" x 1"

#98-122 Lock Washer

#98-116 Flat Washer

#94-150 Channel Nut

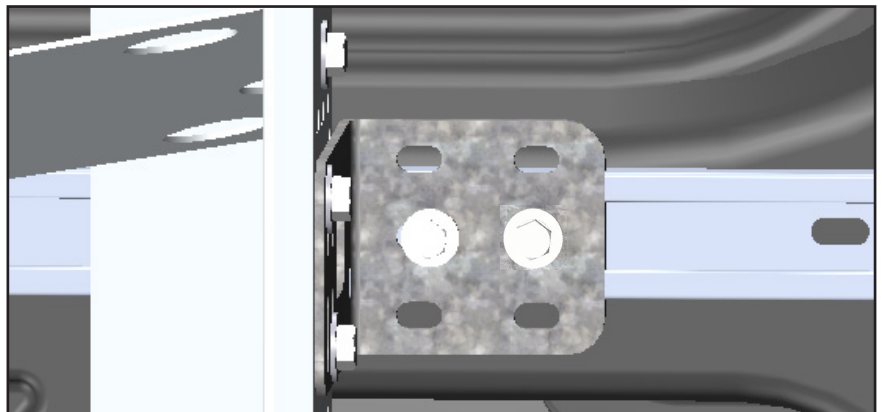

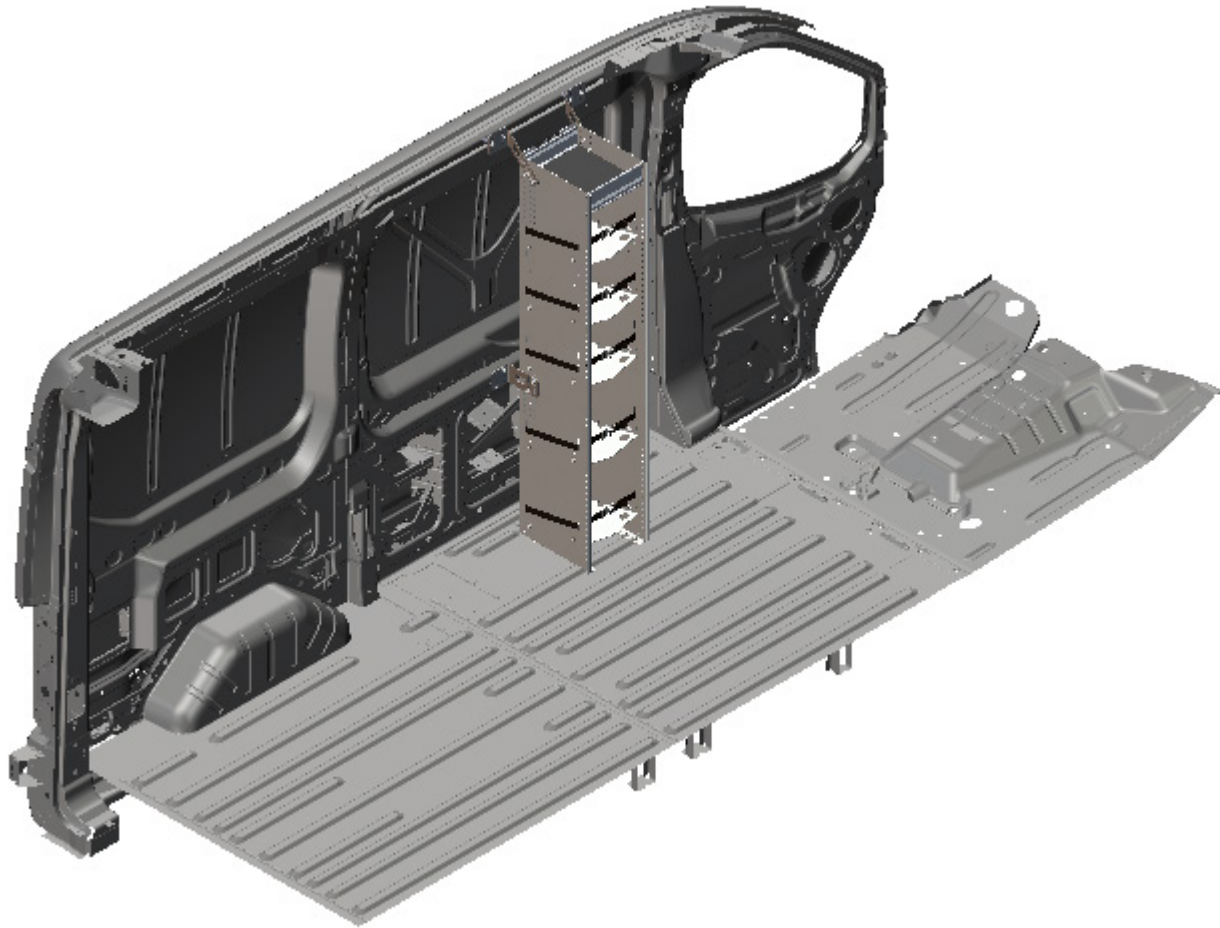

**“You have successfully installed your
C5-BA13-4**

Thank you for doing business with us.”

For any feedback or suggestions you may have, please contact: cs@rangerdesign.com

