

# INSTALLATION GUIDE

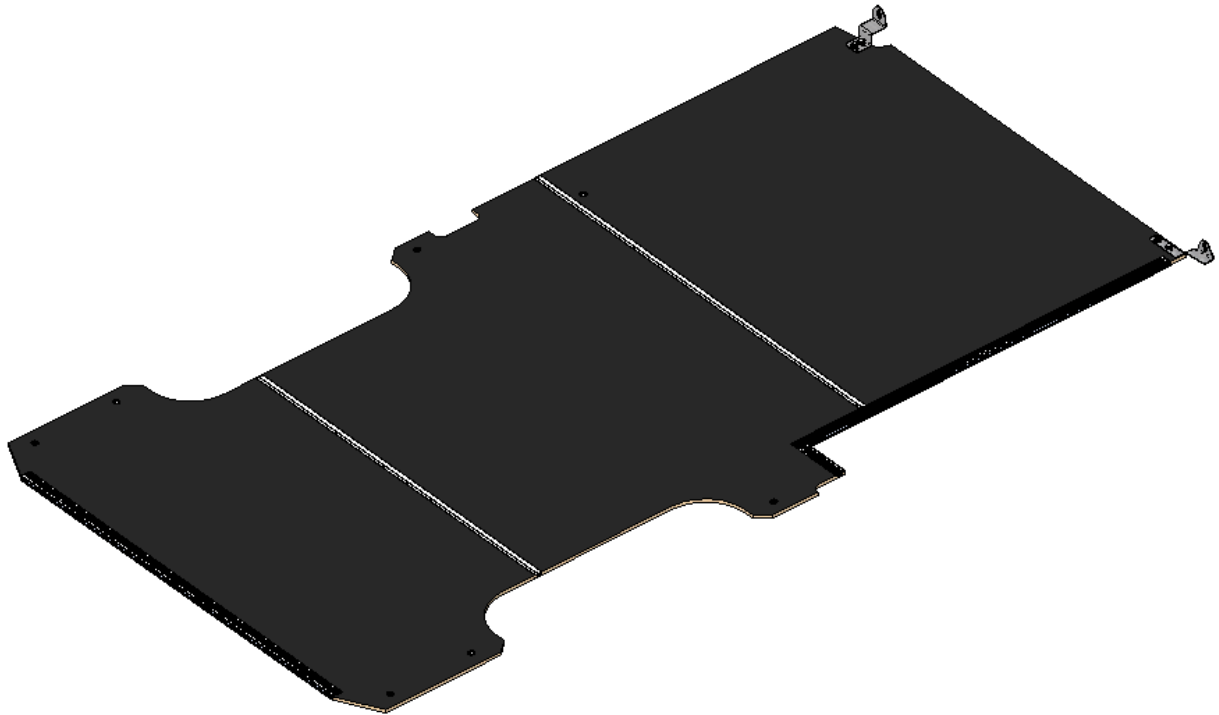

## 6541-DR FLOOR

Sprinter (144" Wheelbase)



Scan the QR for the latest Install-Guide.



# Warnings

READ, UNDERSTAND, AND FOLLOW ALL WARNINGS AND INSTRUCTIONS BEFORE USING THIS PRODUCT. FAILURE TO FOLLOW THESE DIRECTIONS MAY RESULT IN PROPERTY DAMAGE, SERIOUS BODILY INJURY, AND/OR DEATH. RANGER DESIGN IS NOT RESPONSIBLE FOR ANY PROPERTY DAMAGE, PERSONAL INJURY, OR DEATH THAT OCCURS WHILE USING ANY RANGER DESIGN PRODUCTS. THE FINAL ALTERER AND/OR MODIFIER SHOULD REVIEW THE WARNING SHEET WITH THE CUSTOMER BEFORE THE VEHICLE IS RELEASED TO THE CUSTOMER FOR GENERAL USE. THESE INSTRUCTIONS SHOULD REMAIN WITH THE VEHICLE AT ALL TIMES.

## **WARNINGS – Prior To Starting**

- Ranger Design products must be assembled and installed by individuals qualified to use the tools required and have experience with similar products. If there is any question as to competence or experience, please contact a professional alterer or modifier.
- Failure to use Ranger Design-provided fasteners, brackets, and proper installation guidelines could increase risk of serious personal injury and/or death.
- Prior to installation, inspect the vehicle to ensure that installation will not interfere with, or cause obstruction of, any critical components such as electrical wiring, fuel tanks, fuel cells, locks, latches, etc.
- The final alterer and/or modifier is responsible for ensuring all equipment is sufficiently secured to wall and floor structures or suitable anchorages.
- Do not install systems into any weak or unsound materials such as plastics, woods, thin-walled metals, etc., without proper reinforcement.
- Do not install this product where it could interfere with the deployment of airbags. Failure to comply could result in death or serious injury.
- Do not install this product where it could ingress on the Vehicle Occupant Protection Zone. Failure to comply could result in death or serious injury.
- Incorrect installation could cause water leaks, electric shock, or fire.
- Any cargo vehicle with any cargo or equipment should use a certified partition which can be found on the Ranger Design website. (<https://rangerdesign.com>)
- Mounting rails and floors are strongly recommended for any attachment to the vehicle and can be found on the Ranger Design website. (<https://rangerdesign.com>)
- Any modification or unintended use of this product voids any warranty and could create a hazardous condition.
- Ranger Design provides recommended assembly and installation instructions which must be followed to ensure correct operation. Failure to do so could invalidate the product's compliance and/or warranty and cause injury.
- The final stage vehicle alterer and/or modifier is responsible for the integration, installation, and compliance of the product in its final location with all applicable regulations and standards. Failure to maintain compliance of the vehicle with applicable regulations and standards could be punishable by law. Alterers and/or modifiers should consult with all local authorities prior to commissioning.

- Any materials, padding, or glazing installed in the vehicle must comply with FMVSS/CMVSS 201/205/302, as applicable.

## **WARNINGS – Prior To Drilling**

- Improper drilling can cause property damage to vehicles and could lead to electric shock, fire, or even death.
- Ensure that drilling is only performed on areas of the vehicle allowed by the vehicle's Original Equipment Manufacturer's Body Builders Layout Book (or equivalent document).
- Ensure that you will not hit any critical parts of the vehicle like the gas tank, wiring harnesses, or hoses. Consult the vehicle's OEM documentation as necessary. When drilling, use a drill collar to reduce the risk of damage to the vehicle.

## **WARNINGS – Prior To Operating Vehicle**

- The heaviest items must be placed towards the bottom of the vehicle, while the lightest ones can be arranged upwards. Vehicle cargo loading weight proportion should follow the guidelines shown here.
- Check your vehicle's tare weight and remaining load capacity with all equipment installed. Never exceed the maximum Gross Vehicle Weight Rating (GVWR), Gross Axle Weight Ratings (GAWRs), or other maximum loads permitted by the vehicle's Original Equipment Manufacturer (OEM) and required by law.
- All items in the cargo area should be properly secured and partition doors closed while the vehicle is in motion.
- All system components should be regularly inspected, cleaned, and maintained pursuant to Ranger Design guidelines.

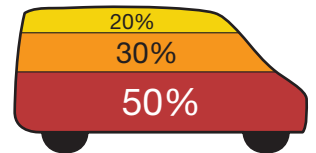

## **WARNING – In Event Of An Accident**

- In the event of a motor vehicle accident or collision where a Ranger Design system has been installed, especially ones where the vehicle's structure has been damaged and/or the air bags have deployed and/or the vehicle has been towed, the system must be inspected to ensure continued soundness and safety before returning the vehicle to service. Damaged components should be replaced as necessary.

FR: Si vous avez besoin de ces instructions en français, s'il vous plait contacter notre service à la clientèle. +1-800-565-5321

ES: Si necesita estas instrucciones en español, comuníquese con el Servicio de atención al cliente de Ranger Design. +1-800-565-5321

# QUICK START GUIDE

## Phase 1 - Assembly

- 1.1 Setup..... 4

## Phase 2 - Installation

- 2.1 Install Preparation.....6
- 2.2 Floor Installation..... 6

## Phase 3 - Add-ons

- 3.1 Typical Unit Installation..... 10

# REQUIRED ITEMS

- Tape Measure
- Rubber Mallet
- Hex Key 13mm
- Hex Key 5mm
- Torx Key T45
- Socket 1/2"
- Wrench 1/2"
- Drill
- Drill Stop Collar
- Drill Bit 7/16"
- Marker

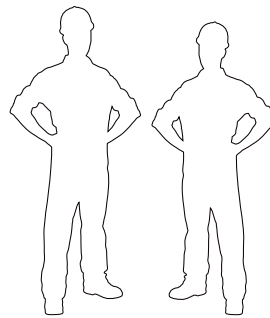

**2**  
**PERSONS**

# PHASE 1 – ASSEMBLY

## 1.1 SETUP

1.1.1 Unpack components; compare with the bill of materials.

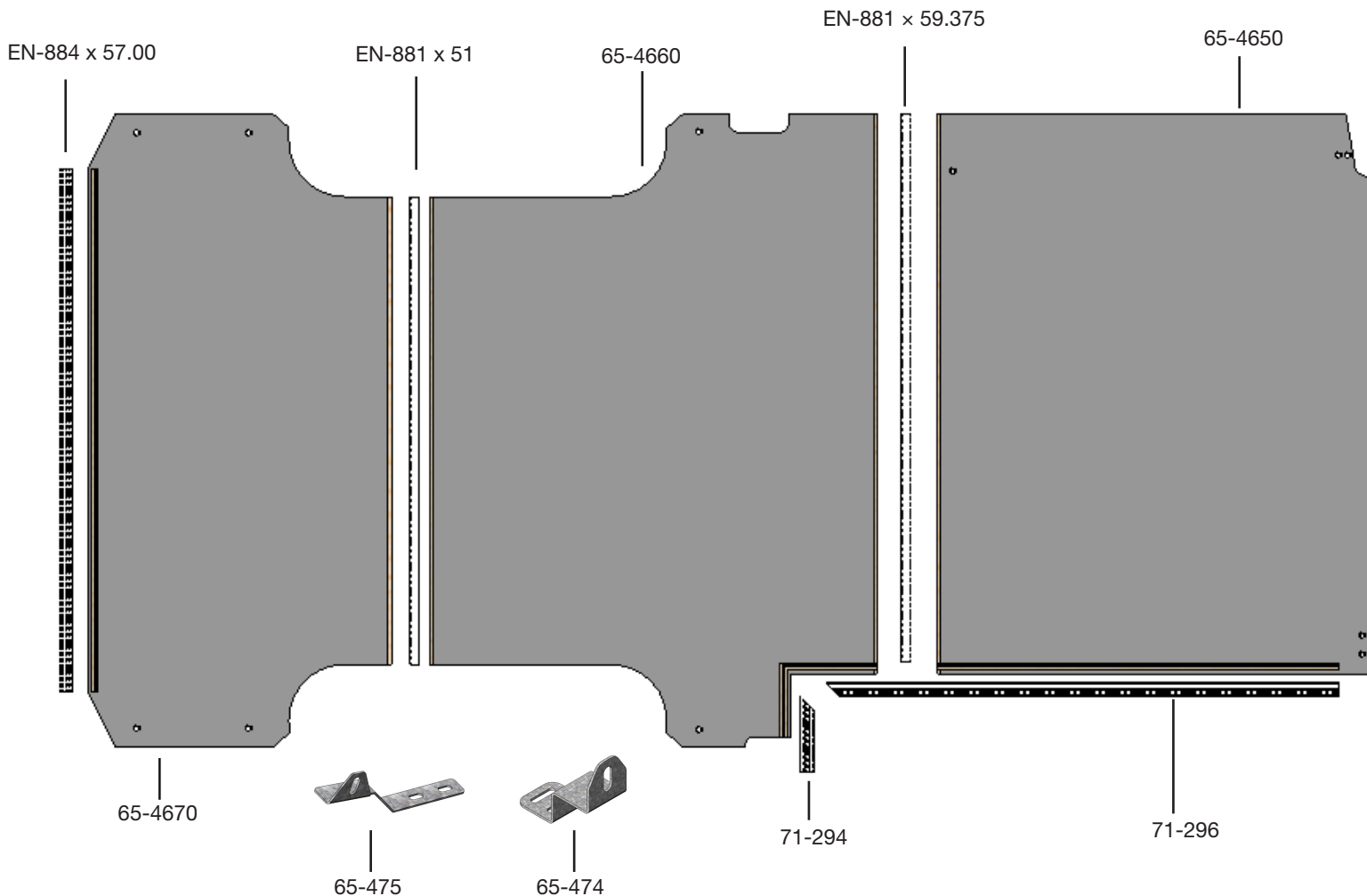

1.1.2 Verify all parts are present.

### BILL OF MATERIALS

Item No.	Description	Qty.
65-4650	Sprinter E-Floor Front Panel	1
65-4660	Sprinter E-Floor Middle Panel	1
65-4670	Sprinter E-Floor Rear Panel	1
65-474	Sprinter E-Floor B-Pillar Bracket, DS	1
65-475	Sprinter E-Floor B-Pillar Bracket, PS	1
71-294	Floor Sill Extrusion, 8.29" W/ One 45 DEG Cut	1
71-296	Floor Sill Extrusion, 55.69" W/ One 45 DEG Cut	1
EN-844 x 57.00	57" Floor Sil Extrusion	1
EN-881 x 51	I-Beam Extrusion 51"	1
EN-881 x 59.375	I-Beam Extrusion 59.375"	1
96-9500	Fastener Kit	1
94-6506	Assembly Fastener Kit	1

1.1.3 Fastener kits.



**96-6500 Fastener Kit**



**Fastener Install**

- 30x  # 90-204 Hex Bolt 5/16"-18 x 3/4" ZINC
- 30x  # 99-114 Wood Inserts 5/16"-18 x 13mm ZINC





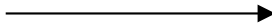

**30x**

 #90-204 Hex Bolt 5/16" x 3/4"  
 #99-114 Wood Inserts 5/16"x13mm

**94-6506 Fastener Kit**



**Fastener Install**

- 9x  # 90-022 Button Head Torx M8-1.25 x 40mm ZINC
- 2x  # 90-023 Guide Pin M8-1.25 x 45mm
- 7x  # 98-157 Spacer 0.375" ID, 1" OD, 0.313" Thick Nylon
- 4x  # 90-204 Hex Bolt 5/16"-18 x 3/4" ZINC
- 4x  # 98-122 Lock Washer 5/16" ZINC
- 13x  # 98-116 Flat Washer 5/16" x 18 ZINC
- 4x  # 99-114 Wood Inserts 5/16"-18 x 13mm ZINC





**7x**

 #90-022 Button Head Torx M8-1.125" x 40mm  
 #98-169 Flat Washer  
 #98-157 Nylon Spacer

**2x**

 #90-022 Button Head Torx M8-1.125" x 40mm  
 #98-169 Flat Washer

**4x**

 #90-204 Hex Bolt 5/16" x 3/4"  
 #98-122 Lock Washer  
 #98-116 Flat Washer  
 #99-114 Wood Inserts 5/16"x13mm

# PHASE 2 – INSTALLATION

## 2.1 INSTALL PREPARATION

2.1.1 Remove all the D-rings and set aside for future setps.

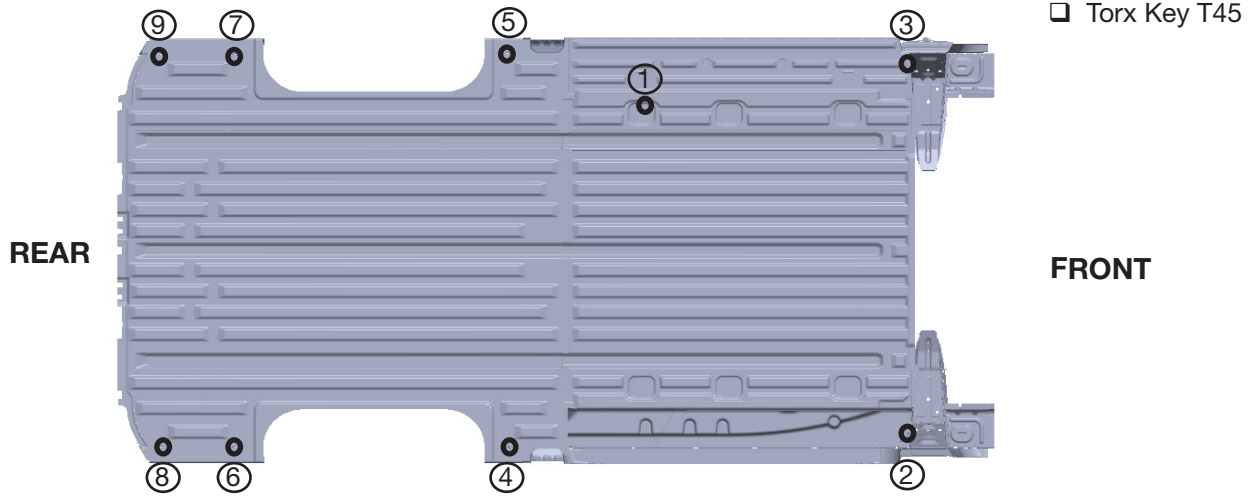

## 2.2 FLOOR INSTALLATION

2.2.1 Place guide-pin & spacers in marked locations.

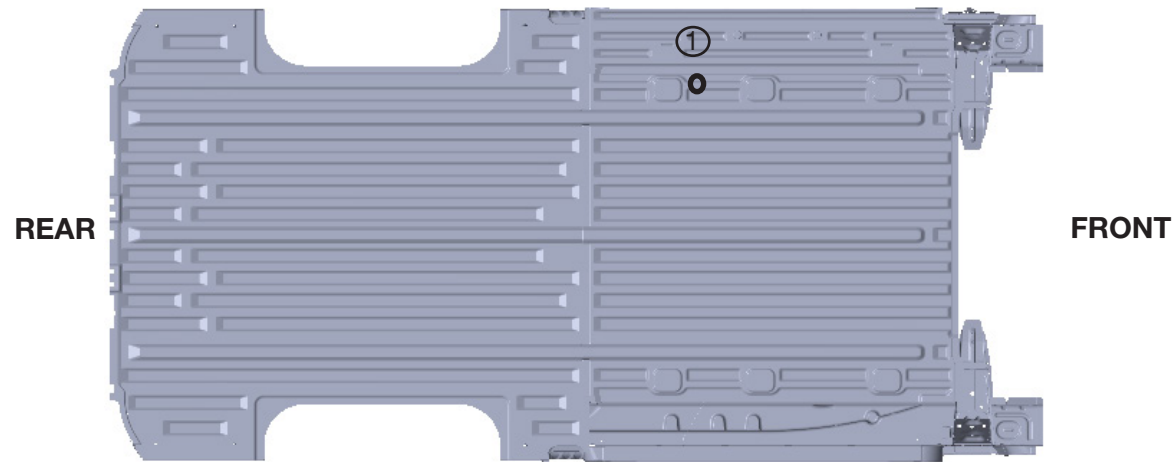

90-023  
98-157

Guide pin (90-023) does not need to be fully threaded. This is to prevent the spacers from moving when installing the floor.

**TOOLS**  
□ Hex Key 5mm

**HARDWARE USED**  
**2X**

- #90-023 Guide pin
- #98-157 Spacer

**2.2.2** Place floor, remove Pins and set aside for future steps, add Hardware & D-Rings.

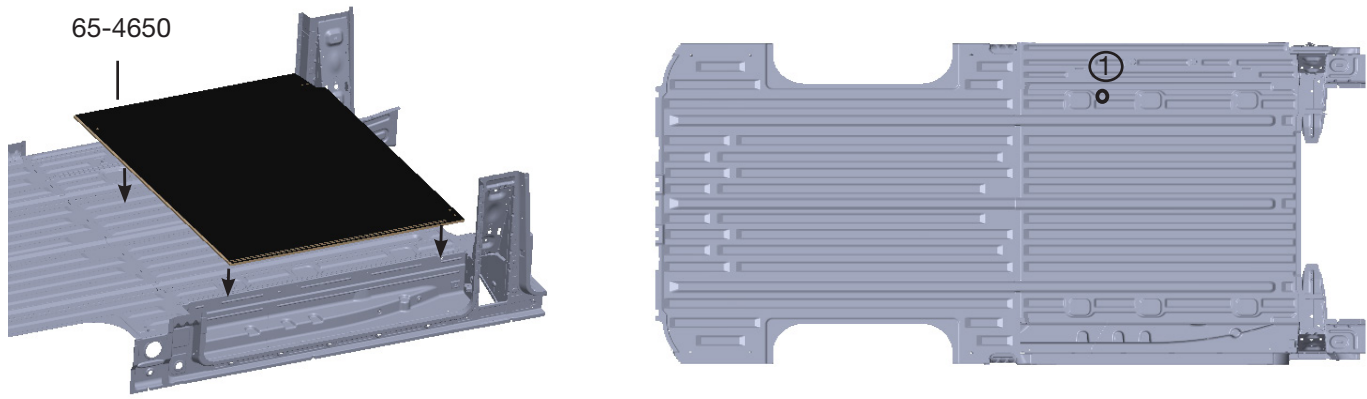

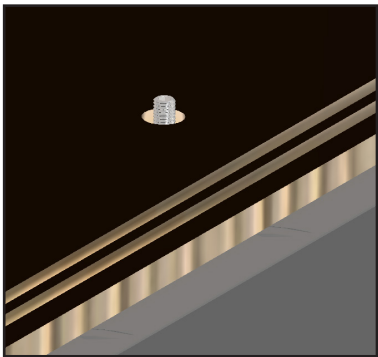

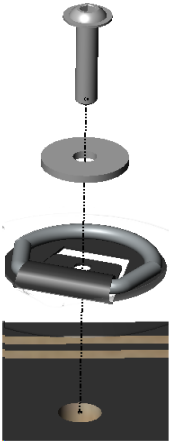





**TOOLS**

- ☐ T45 Torx key

**HARDWARE USED**



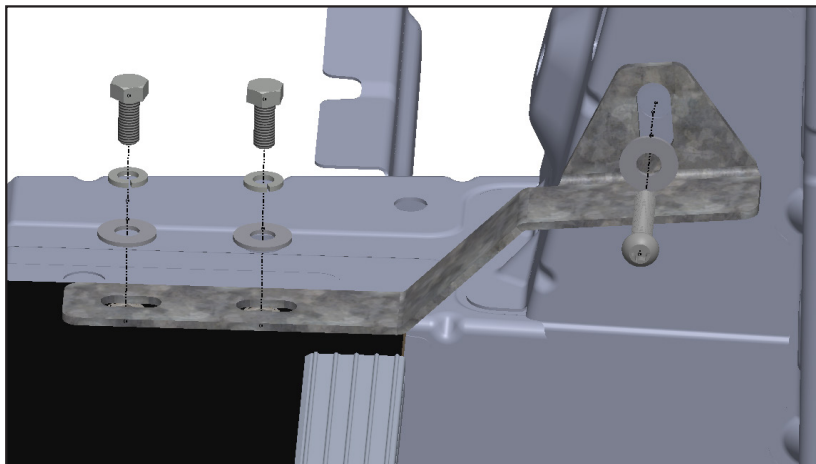

**1x** (11 ft • lbs)

-  #90-022 Button Head Torx
-  #98-116 Flat Washer Steel
-  D-Ring
-  Floor
-  #98-157 Spacer - installed in previous step



**2.2.3** Install B-pillar bracket.



- TOOLS**
- ☐ Impact
  - ☐ 1/2" Socket
  - ☐ 13mm hex key
- HARDWARE USED**
- 2x** (12 ft • lbs)

-  #90-204 Hex Bolt
  -  #98-112 Lock Washer
  -  #98-116 Flat Washer ZINC
  -  #99-114 Wood Inserts

- TOOLS**
- ☐ T45 Socket
  - ☐ Impact
  - ☐ 1/2" Socket
  - ☐ 13mm hex key
- HARDWARE USED**
- 1x** (11 ft • lbs)

-  #90-022 Button Head Torx
  -  #98-116 Flat Washer

**2.2.4** Install B-pillar bracket.

**TOOLS**

- Impact
- 1/2" Socket
- 13mm hex key

**HARDWARE USED**

**2x** (12 ft • lbs)

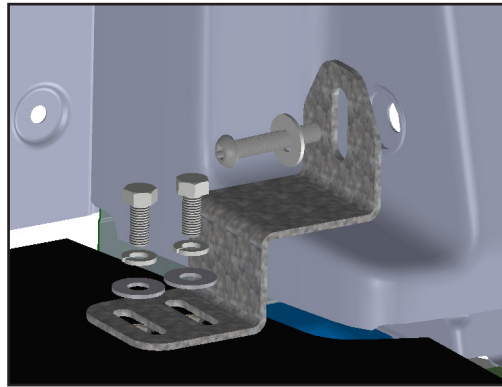
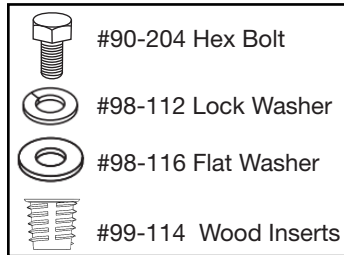

**TOOLS**

- T45 Socket
- Impact
- 1/2" Socket
- 13mm hex key

**HARDWARE USED**

**1x** (11 ft • lbs)

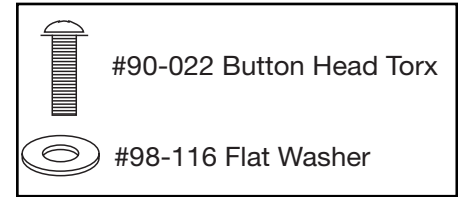

**2.2.5** Install "I" beam to first floor piece.

EN-881 x 59.375

65-4650

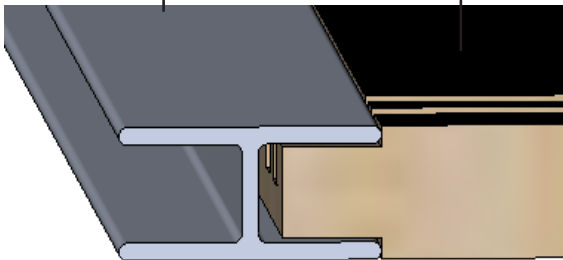

**2.2.6** Add guide pins, place floor, remove pins and set aside for future steps, add hardware & d-rings.

65-4660

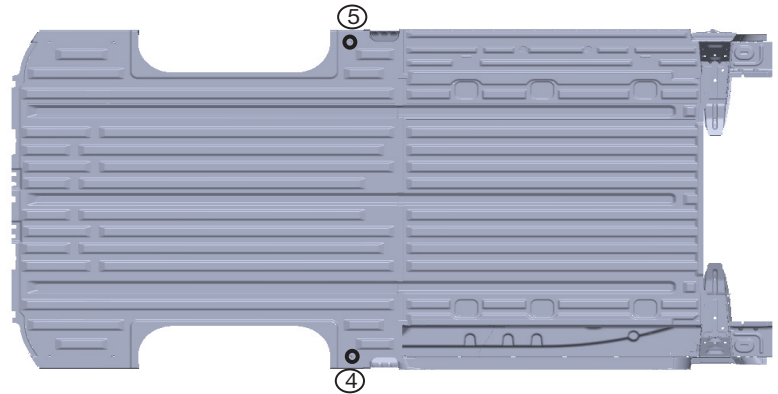
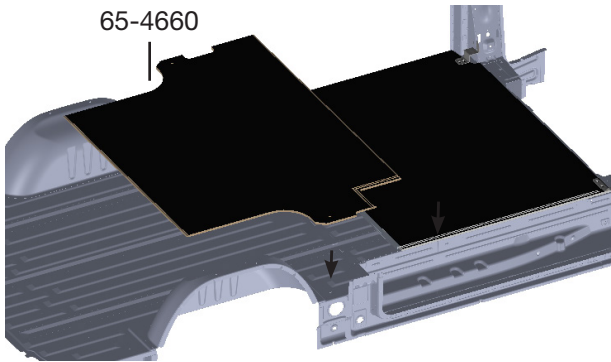

**TOOLS**

- T45 Torx key

**HARDWARE USED**

**2x** (11 ft • lbs)

- #90-022 Button Head Torx
- #98-116 Flat Washer Steel
- D-Ring
- Floor
- #98-157 Spacer - installed in previous step



**2.2.7** Install “I” beam to first floor piece.

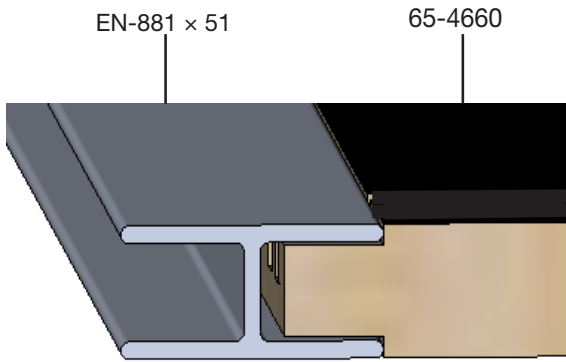

**2.2.8** Add guide pins, place floor, remove pins and set aside for future steps, add hardware & d-rings.

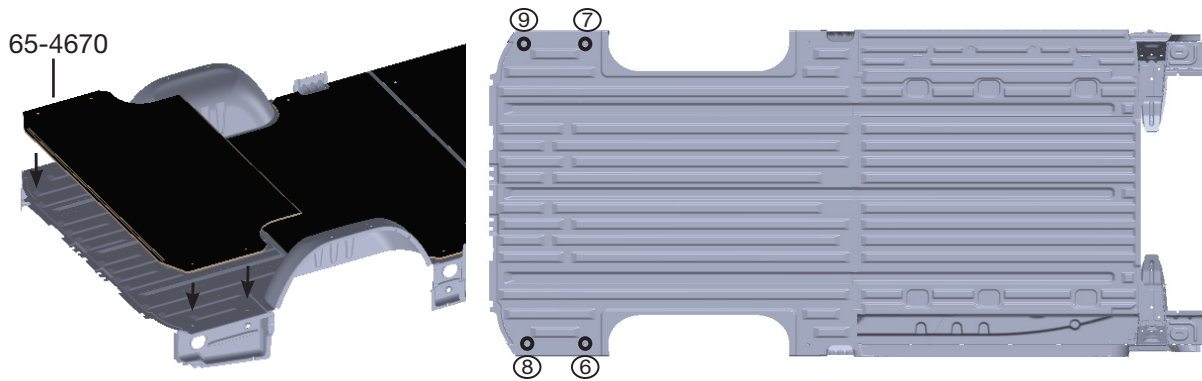

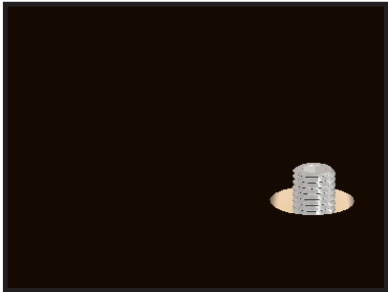

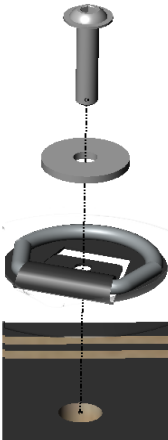





**TOOLS**

- T45 Torx key

**HARDWARE USED**

**4x** (11 ft • lbs)

-  #90-022 Button Head Torx
-  #98-116 Flat Washer Steel
-  D-Ring
-  Floor
-  #98-157 Spacer - installed in previous step

2.2.9 Install FRONT & REAR sill extrusion.

**FRONT & REAR SILL INSTALLATION**

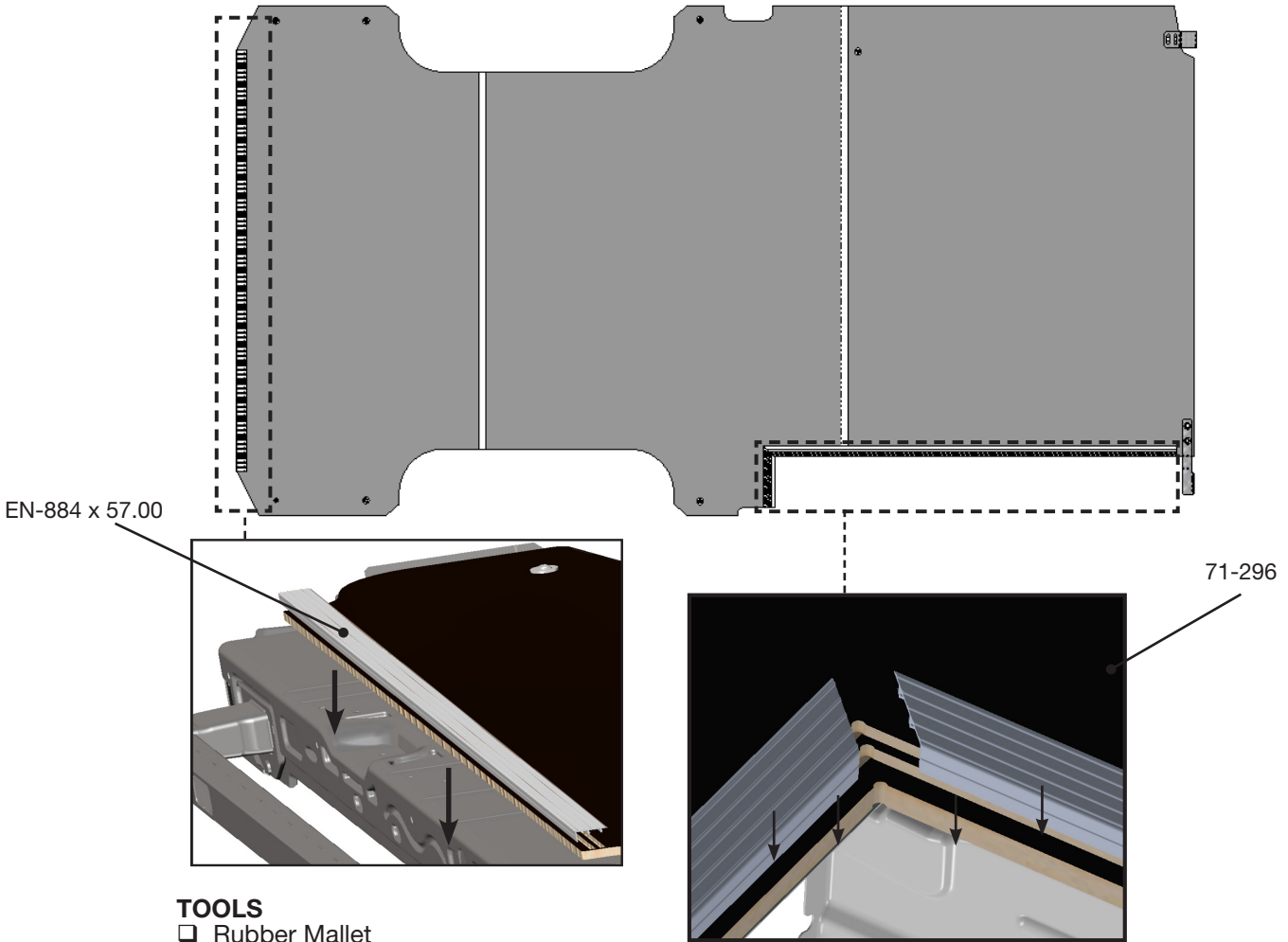

- TOOLS**
- Rubber Mallet

**NOTE:** Line up sill extrusion correctly before pressing it in. Use rubber mallet when needed.

**PHASE 3 – ADD-ONS**

**3.1 TYPICAL UNIT INSTALLATION**

- |  |                                    |
|--|------------------------------------|
|  | #90-204 Hex Bolt<br>5/16" x 3/4"   |
|  | #99-114 Wood Inserts<br>5/16"x13mm |
|  | Floor                              |

- TOOLS**
- Hex Key 5/16"
  - Drill
  - Drill Stop Collar
  - Drill Bit 7/16"
  - Wrench 1/2"

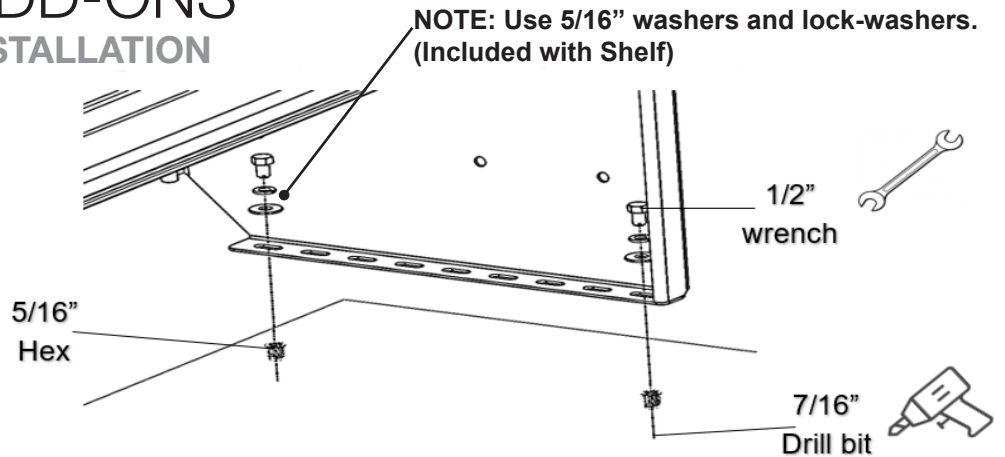

**“You have successfully installed your E-Floor, thank you for doing business with us.”**  
 For any feedback or suggestions, you may have, please contact: [cs@rangerdesign.com](mailto:cs@rangerdesign.com)