

INSTALLATION GUIDE

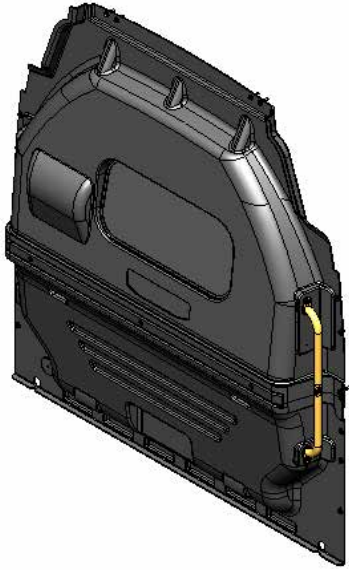

3310-FTH

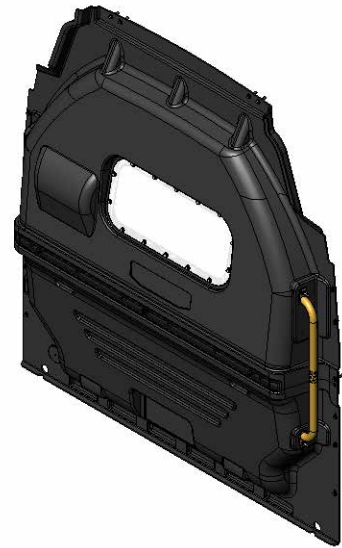

3320-FTH

Composite Partition

Ford Transit High Roof



Scan the QR for the latest Install-Guide.





BEFORE YOU BEGIN

READ, UNDERSTAND, AND FOLLOW ALL WARNINGS AND INSTRUCTIONS BEFORE USING THIS PRODUCT. FAILURE TO FOLLOW THESE DIRECTIONS MAY RESULT IN PROPERTY DAMAGE, SERIOUS BODILY INJURY, AND/OR DEATH. RANGER DESIGN IS NOT RESPONSIBLE FOR ANY PROPERTY DAMAGE, PERSONAL INJURY, OR DEATH THAT OCCURRED WHILE USING ANY RANGER DESIGN PRODUCTS.



WARNING

- Failure to use Ranger Design-provided fasteners, brackets, and proper installation guidelines could increase risk of serious personal injury and/or death.
- If drilling is required to complete this installation: improper drilling can cause property damage to vehicles and could lead to electric shock, fire, or even death.
- If drilling is required to complete this installation: Ensure that drilling is only performed on areas of the vehicle allowed by the vehicle's Original Equipment Manufacturer's Body Builders Layout Book (or equivalent document).
- Prior to installation, inspect the vehicle to ensure that installation will not interfere with, or cause obstruction of, any critical components such as electrical wiring, fuel tanks, fuel-cells, locks, latches, etc.
- The installer or manufacturer is responsible for ensuring anchorages are installed onto suitable wall and floor structures; wall and floor strength must meet applicable performance requirements.
- Do not install systems into any weak or unsound materials such as plastics, woods, thin-walled metals, etc. without proper reinforcement.
- Do not install this product where it could interfere with the deployment of airbags. Failure to comply could result in death or serious injury.
- Do not install this product where it could ingress on the Transit Occupant Protection Zone. Failure to comply could result in death or serious injury.
- Incorrect installation could cause water leaks, electric shock or fire.
- Any cargo vehicle with any cargo or equipment should use a certified partition. See Ranger Design website for some partition options. (<https://rangerdesign.com/>)
- Mountings rails are recommended for any attachment to the vehicle walls.
- All items in the cargo area should be properly secured and partition doors closed while the vehicle is in motion.
- Check your vehicle's tare weight and remaining load capacity with all the equipment installed. Never exceed the maximum Gross Vehicle Weight Rating (GVWR), Gross Axle Weight Ratings (GAWRs), or other maximum loads permitted by the vehicle's Original Equipment Manufacturer (OEM) and required by law.
- The heaviest items must be placed towards the bottom of the vehicle, while the lightest ones can be arranged upwards. Vehicle cargo loading weight proportion should follow the following guidelines:

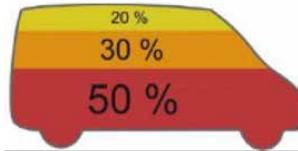

- The final alterer and/ or modifier should review the warning sheet with the customer before the vehicle is released to the customer or for general use. These instructions should remain with the vehicles a all times.
- Any modification or unintended use of this product voids any warranty and could create a hazardous condition.
- Ranger Design provides recommended assembly and installation instructions which should be followed to ensure correct operation. Failure to do so could result in invalidating the product's compliance, warranty and cause injury. Notwithstanding, the final stage vehicle alterer and/or modifier is responsible for the integration, installation, and compliance of the product in its final location to all applicable regulations and standards. Failure to maintain compliance of the vehicle to applicable regulations and standards could be punishable by law. Alterers and/or modifiers should consult with all local authorities prior to commissioning.



CAUTION

- Drilling is required to complete this installation. Before drilling, ensure that you will not hit any critical parts of the vehicle like the gas tank, wiring harness, or hose. Consult the vehicle OEM documentation as necessary. When drilling, use a drill collar to reduce the risk of damage to the vehicle.
- Any materials, padding, or glazing installed in the vehicle must comply with FMVSS/CMVSS 201/205/302, as applicable.
- In the event of a motor vehicle accident or collision where a Ranger system has been installed, especially ones where the vehicle structure is damaged and/or the air bags deploy and/or the vehicle has been towed, the system must be inspected to ensure continued soundness and safety before returning the vehicle to service. Damaged components should be replaced as necessary.
- All system components should be regularly inspected, cleaned, and maintained pursuant to Ranger guidelines.

QUICK START GUIDE

Phase 1 - Assembly

| | |
|--|---|
| <input type="checkbox"/> 1.1 Setup..... | 4 |
| <input type="checkbox"/> 1.2 Partition Assembly..... | 6 |

Phase 2 - Install

| | |
|--|----|
| <input type="checkbox"/> 2.1 Vehicle Preparation..... | 7 |
| <input type="checkbox"/> 2.2 Partition Installation..... | 9 |
| <input type="checkbox"/> 2.3 Handle Installation..... | 11 |

REQUIRED ITEMS

- Cordless Impact
- Cordless Drill
- Marker
- Plusnut Tool
- Tape Measure
- 3/8" Drill Bit
- 7/16" Socket
- 1/2" Socket
- 9/16" Wrench
- 10mm Socket
- Drill Stop

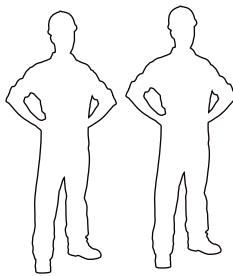

**2
PERSONS**

PHASE 1 – ASSEMBLY

1.1 SETUP

1.1.1 Unpack components; compare with the bill of materials.

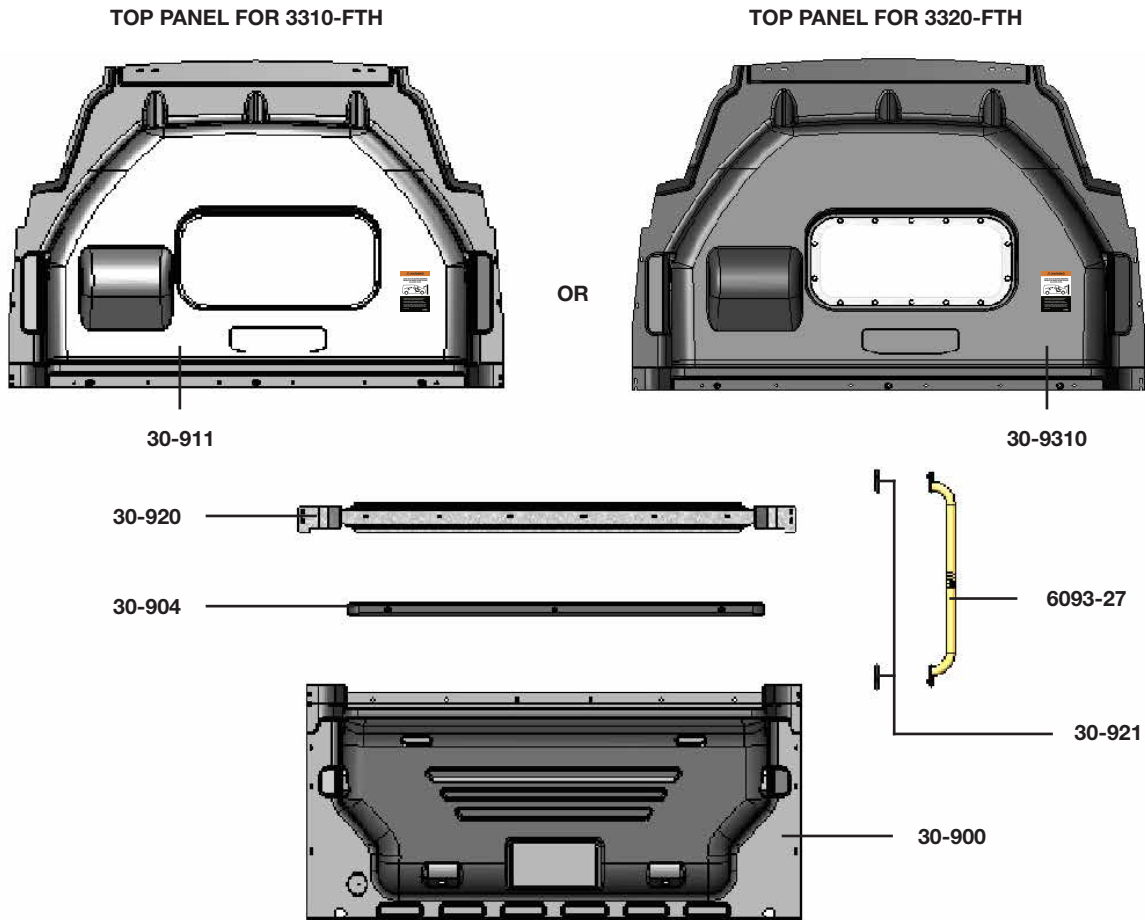

1.1.2 Verify all parts are present.

| Item No. | Description | Qty. |
|-------------------|--------------------------------------|------|
| 30-900 | Bottom Panel | 1 |
| 30-904 | Bolt Cap | 1 |
| 30-911 OR 30-9310 | Top Panel | 1 |
| 30-920 | Support | 1 |
| 30-921 | Handle Plate | 2 |
| 6093-27 | Large Grab Handle | 1 |
| 94-5017 | Assembly Fastener Kit | 1 |
| 96-3040 | Install Fastener Kit | 1 |
| 79-932 | Warning label - Bilingual, partition | 1 |



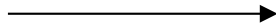

1.1.3 Identify the **Assembly** and **Installation** fastener bags.

94-5017



Hardware Assembly

x6

| | |
|---|--------------------------|
|  | #90-490 Carriage Bolt 1" |
|  | #98-116 Flat Washer |
|  | #98-122 Lock Washer |
|  | #94-104 Hex Nut |

x3



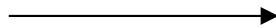

| | |
|---|-----------------------------|
|  | #99-109 Christmas tree plug |
|---|-----------------------------|

96-3040







Hardware Assembly



x4

| | |
|---|--------------------------------|
|  | #90-118 Hex Bolt 1/4" x 1-1/4" |
|  | #98-118 Lock Washer |
|  | #98-112 Flat Washer |
|  | #94-130 Plusnut |

x7

| | |
|---|---------------------------|
|  | #94-100 Double Ended Bolt |
|  | #98-118 Lock Washer |
|  | #98-112 Flat Washer |
|  | #90-983 Double Ended Bolt |
|  | #94-130 Plusnut |

x5

| | |
|---|--------------------------------|
|  | #90-971 Hex Bolt M6-1.0 x 20mm |
|  | #98-118 Lock Washer |
|  | #98-112 Flat Washer |

PHASE 1 – ASSEMBLY

1.2 PARTITION ASSEMBLY

1.2.1 Attach the top and bottom panel with support bracket.

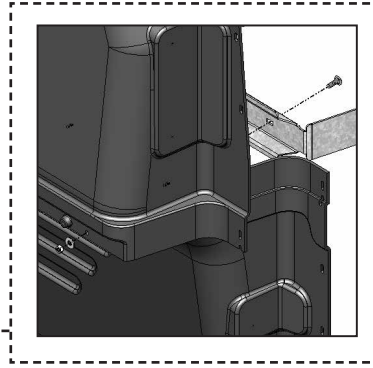
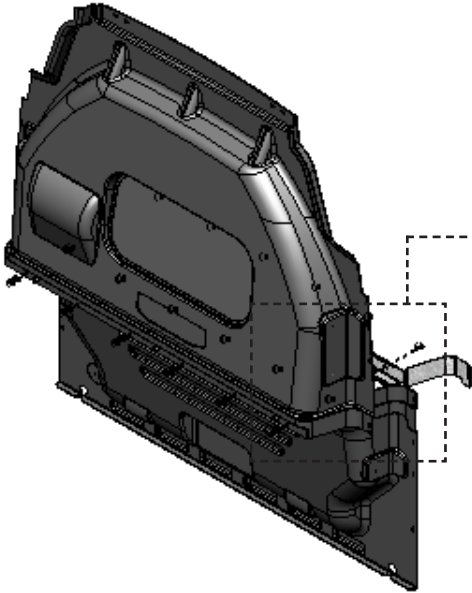

TOOLS

- Cordless Impact
- 1/2" Socket

HARDWARE USED

6x



#90-490 Carriage Bolt 1"



#98-116 Flat Washer



#98-122 Lock Washer



#94-104 Hex Nut

1.2.2 Plug the Bolt cap to the partition using Christmas tree plug.

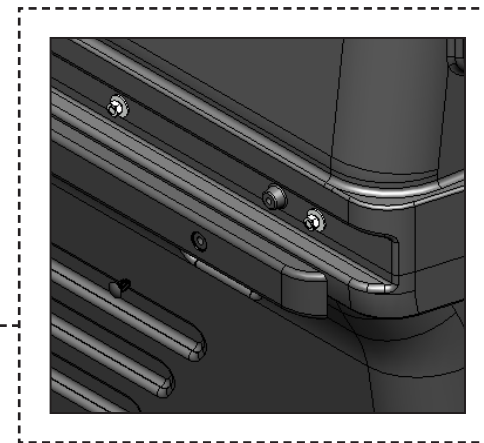
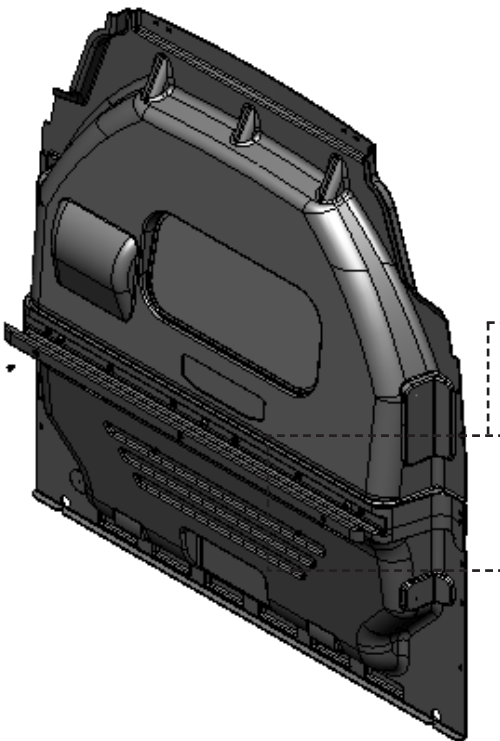

HARDWARE USED

3x



#99-109 Christmas tree plug

PHASE 2 – INSTALL

2.1 VEHICLE PREPARATION

2.1.1 Driver and passenger sides preparation.

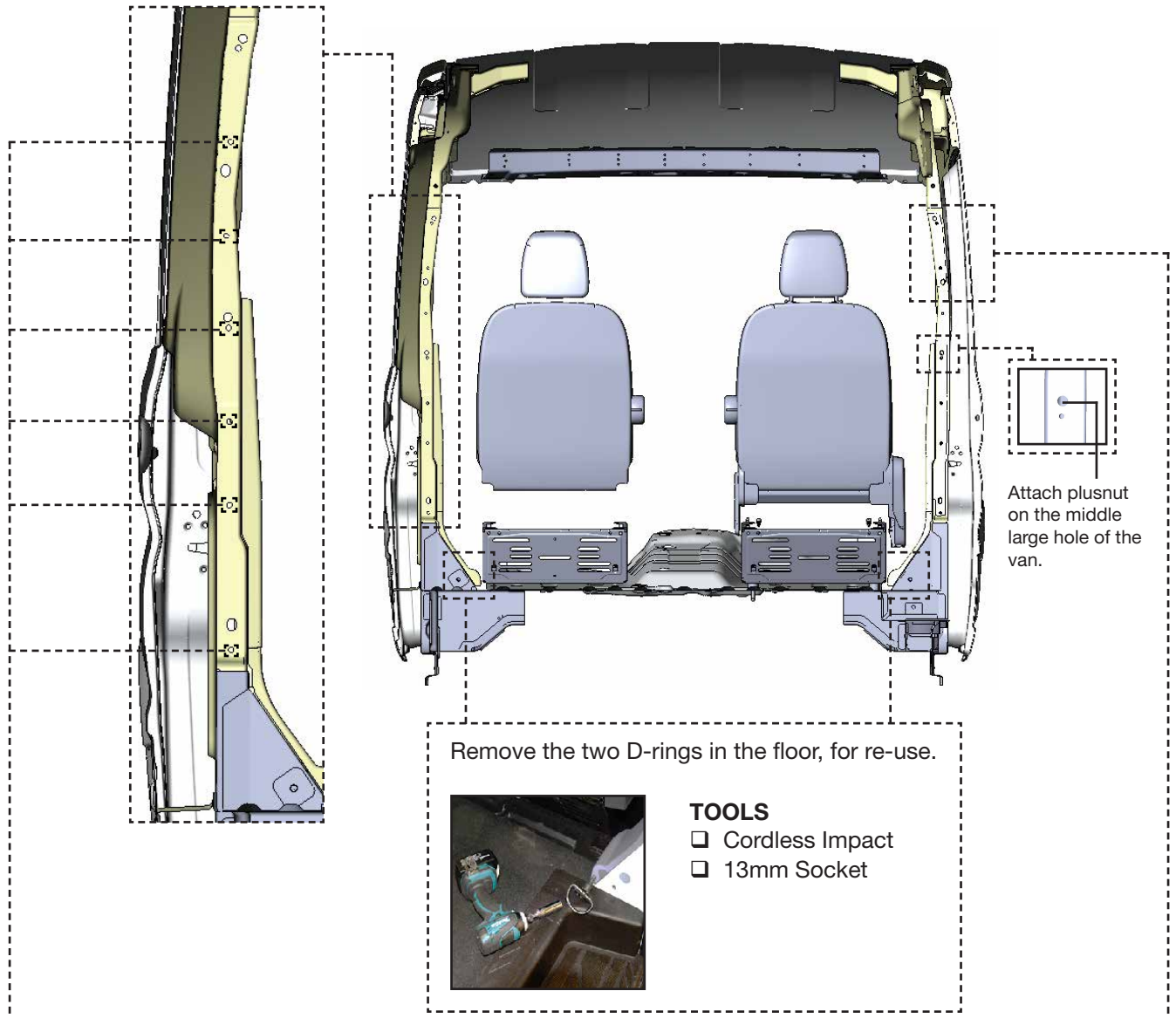

Attach plusnuts on the five factory holes.

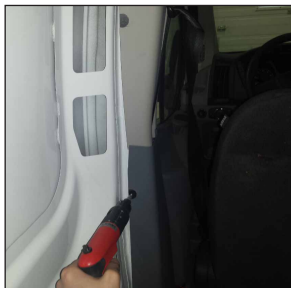

TOOLS

- Plusnut Tool

HARDWARE USED

6x



94-130
Plusnut .250

Remove the factory handle in the van.

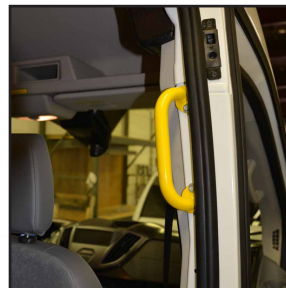

TOOLS

- Cordless Impact
- 10mm Socket

2.1.2 Ceiling preparation.

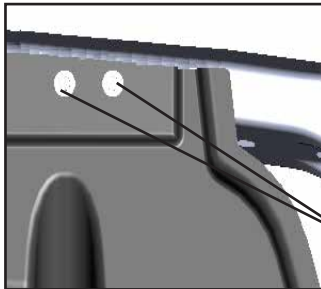
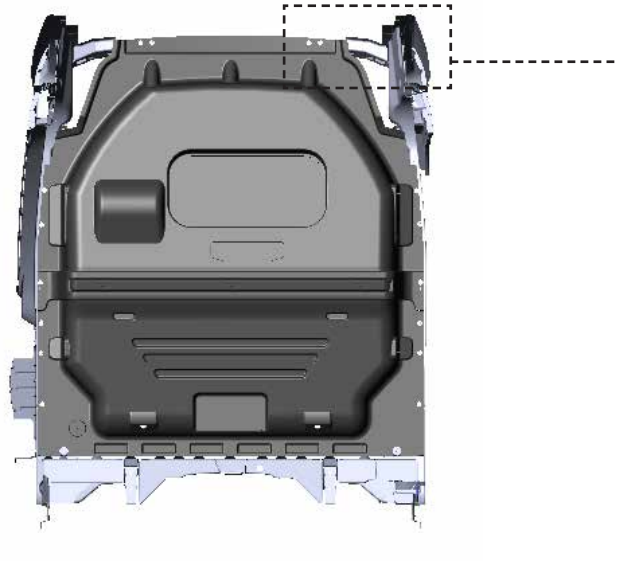

Lift the assembled partition inside the van and put it in place, then put 4 marks on the van through the holes of the top panel.

MARKS

TOOLS

- Marker



Put the assembled partition on the side, then drill the 4 marks using the 3/8" drill bit or step drill.

TOOLS

- Cordless Drill
- 3/8" Drill Bit or Step Drill
- Drill Stop



Attach plusnuts in the 4 holes.

TOOLS

- Plusnut Tool

HARDWARE USED

4x



94-130
Plusnut .250

PHASE 2 – INSTALLATION

2.2 PARTITION INSTALLATION

2.2.1 Install double ended bolt into plus nuts installed in previous step

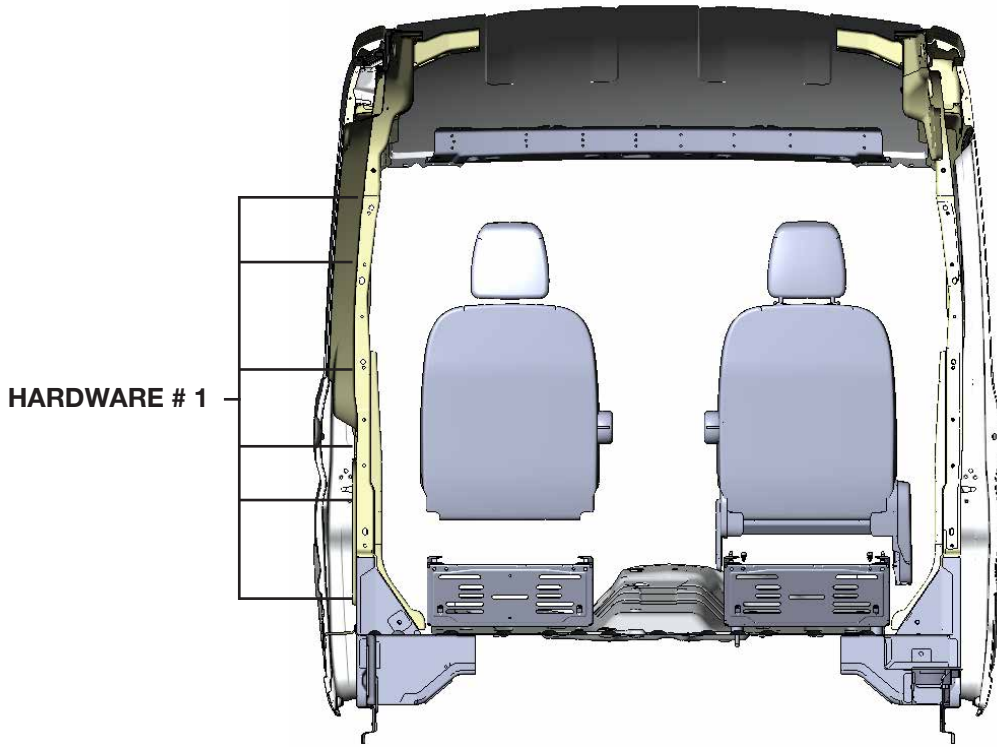

HARDWARE # 1

TOOLS

- Cordless Impact
- 7/16" Socket

HARDWARE USED

7x



#90-983 Double Ended Bolt



#94-130 Plusnut

2.2.2 Lift and place the partition back on the van, then attach the partition to the van.

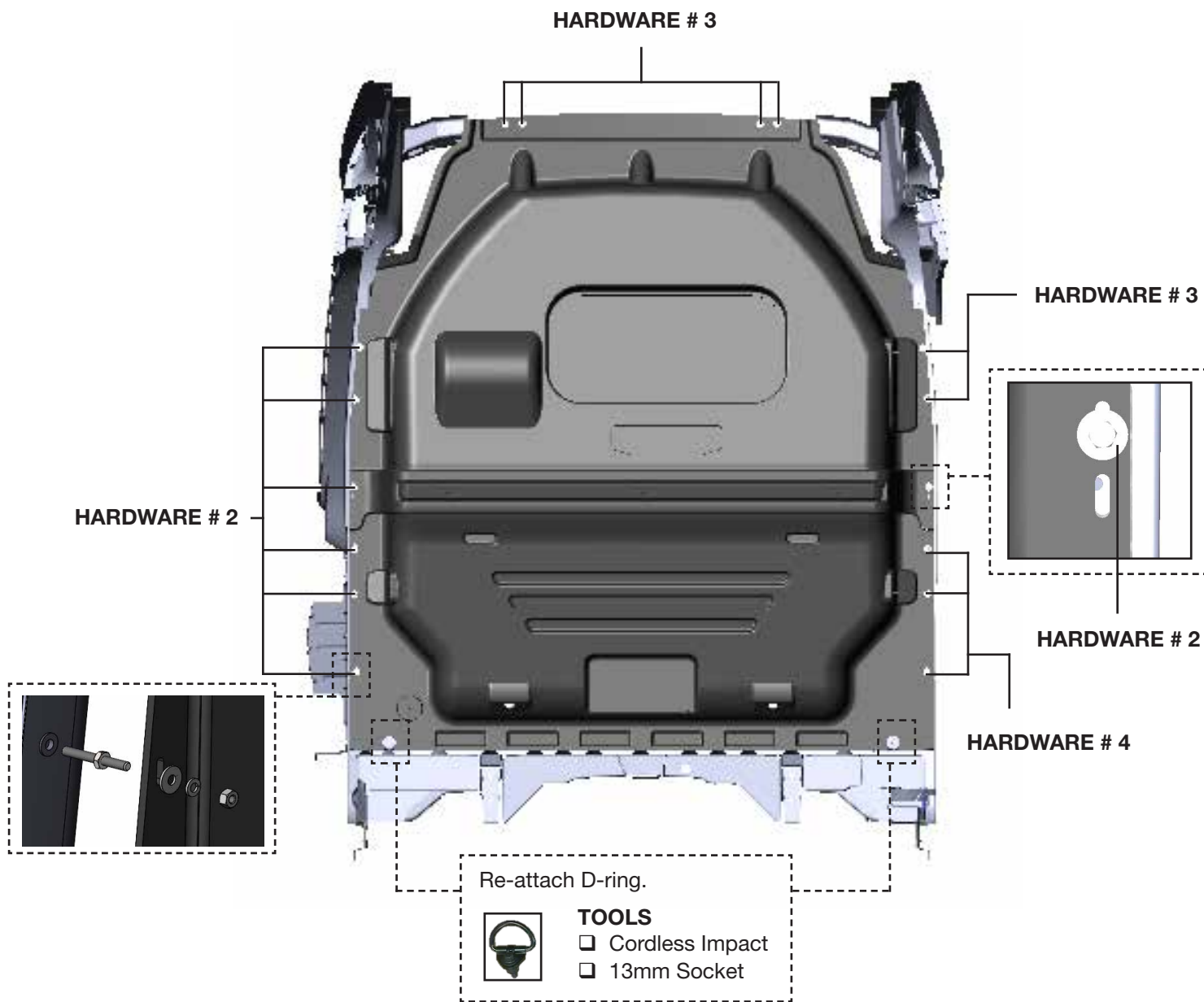

HARDWARE # 2

TOOLS

- Cordless Impact
- 7/16" Socket

HARDWARE USED

7x

- #94-100 Double Ended Bolt
- #98-118 Lock Washer
- #98-112 Flat Washer

HARDWARE # 3

TOOLS

- Cordless Impact
- 7/16" Socket

HARDWARE USED

4x

- #90-118 Hex Bolt
1/4" x 1-1/4"
- #98-118 Lock Washer
- #98-112 Flat Washer

HARDWARE # 4

TOOLS

- Cordless Drill
- 10mm Socket

HARDWARE USED

5x

- #90-971 Hex Bolt
M6-1.0 x 20mm
- #98-118 Lock Washer
- #98-112 Flat Washer

PHASE 2 – INSTALLATION

2.3 HANDLE INSTALLATION

2.3.3 Attach the handle on the passenger side of the van.

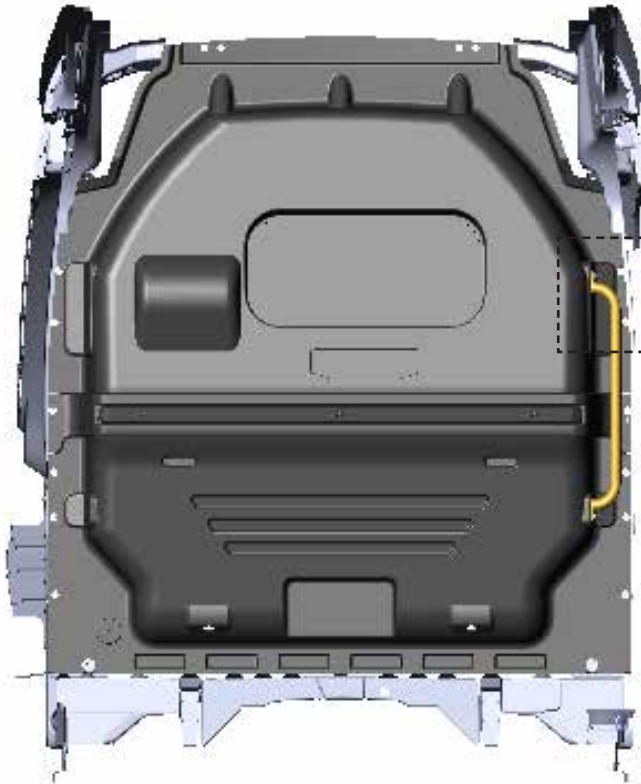

INSIDE



FLAT WASHER

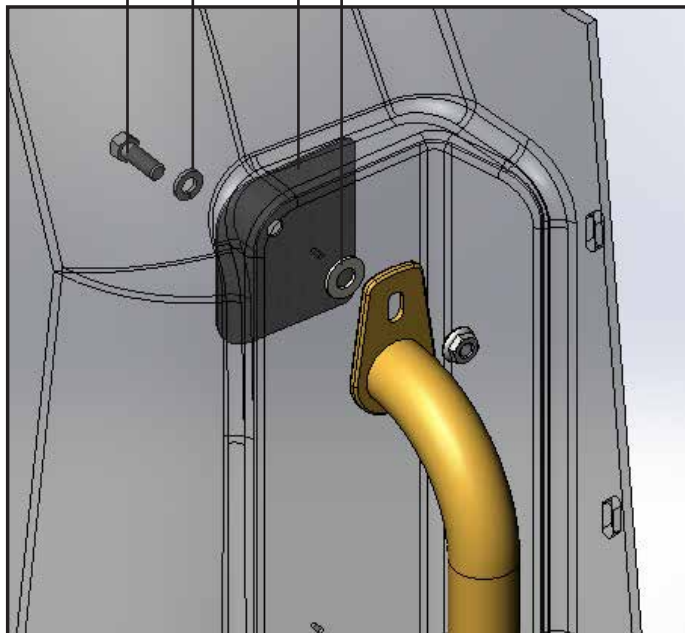

NOTE: You need to enlarge the hole in the partition panel.

TOOLS

- Cordless Impact
- Cordless Drill
- 1/2" Socket
- 3/8" Drill Bit
- Drill Stop

HARDWARE USED

2x GRAB HANDLE FASTENER KIT



#90-206 Hex Bolt 5/16" x 7/8"



#98-122 Lock Washer



#98-116 Flat Washer



#94-116 Serrated Nut

**“You have successfully installed your partition,
Thank you for doing business with us.”**

For any feedback or suggestions, you may have, please contact: cs@rangerdesign.com