

# INSTALLATION GUIDE



## 1506-FTX CARGO +

Ford Transit 148" EXT Wheelbase



Scan the QR for the latest Install-Guide.





# BEFORE YOU BEGIN

READ, UNDERSTAND, AND FOLLOW ALL WARNINGS AND INSTRUCTIONS BEFORE USING THIS PRODUCT. FAILURE TO FOLLOW THESE DIRECTIONS MAY RESULT IN PROPERTY DAMAGE, SERIOUS BODILY INJURY, AND/OR DEATH. RANGER DESIGN IS NOT RESPONSIBLE FOR ANY PROPERTY DAMAGE, PERSONAL INJURY, OR DEATH THAT OCCURRED WHILE USING ANY RANGER DESIGN PRODUCTS.



## WARNING

- Failure to use Ranger Design-provided fasteners, brackets, and proper installation guidelines could increase risk of serious personal injury and/or death.
- If drilling is required to complete this installation: improper drilling can cause property damage to vehicles and could lead to electric shock, fire, or even death.
- If drilling is required to complete this installation: Ensure that drilling is only performed on areas of the vehicle allowed by the vehicle's Original Equipment Manufacturer's Body Builders Layout Book (or equivalent document).
- Prior to installation, inspect the vehicle to ensure that installation will not interfere with, or cause obstruction of, any critical components such as electrical wiring, fuel tanks, fuel-cells, locks, latches, etc.
- The installer or manufacturer is responsible for ensuring anchorages are installed onto suitable wall and floor structures; wall and floor strength must meet applicable performance requirements.
- Do not install systems into any weak or unsound materials such as plastics, woods, thin-walled metals, etc. without proper reinforcement.
- Do not install this product where it could interfere with the deployment of airbags. Failure to comply could result in death or serious injury.
- Do not install this product where it could ingress on the Transit Occupant Protection Zone. Failure to comply could result in death or serious injury.
- Incorrect installation could cause water leaks, electric shock or fire.
- Any cargo vehicle with any cargo or equipment should use a certified partition. See Ranger Design website for some partition options. (<https://rangerdesign.com/>)
- Mountings rails are recommended for any attachment to the vehicle walls.
- All items in the cargo area should be properly secured and partition doors closed while the vehicle is in motion.
- Check your vehicle's tare weight and remaining load capacity with all the equipment installed. Never exceed the maximum Gross Vehicle Weight Rating (GVWR), Gross Axle Weight Ratings (GAWRs), or other maximum loads permitted by the vehicle's Original Equipment Manufacturer (OEM) and required by law.
- The heaviest items must be placed towards the bottom of the vehicle, while the lightest ones can be arranged upwards. Vehicle cargo loading weight proportion should follow the following guidelines:

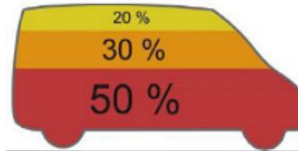

- The final alterer and/ or modifier should review the warning sheet with the customer before the vehicle is released to the customer or for general use. These instructions should remain with the vehicles at all times.
- Any modification or unintended use of this product voids any warranty and could create a hazardous condition.
- Ranger Design provides recommended assembly and installation instructions which should be followed to ensure correct operation. Failure to do so could result in invalidating the product's compliance, warranty and cause injury. Notwithstanding, the final stage vehicle alterer and/or modifier is responsible for the integration, installation, and compliance of the product in its final location to all applicable regulations and standards. Failure to maintain compliance of the vehicle to applicable regulations and standards could be punishable by law. Alterers and/or modifiers should consult with all local authorities prior to commissioning.



## CAUTION

- Drilling is required to complete this installation. Before drilling, ensure that you will not hit any critical parts of the vehicle like the gas tank, wiring harness, or hose. Consult the vehicle OEM documentation as necessary. When drilling, use a drill collar to reduce the risk of damage to the vehicle.
- Any materials, padding, or glazing installed in the vehicle must comply with FMVSS/CMVSS 201/205/302, as applicable.
- In the event of a motor vehicle accident or collision where a Ranger system has been installed, especially ones where the vehicle structure is damaged and/or the air bags deploy and/or the vehicle has been towed, the system must be inspected to ensure continued soundness and safety before returning the vehicle to service. Damaged components should be replaced as necessary.
- All system components should be regularly inspected, cleaned, and maintained pursuant to Ranger guidelines.

# QUICK START GUIDE

## Phase 1 - Set-up

<input type="checkbox"/> 1.1 Setup.....	4
---	---

## Phase 2 - Install

<input type="checkbox"/> 2.1 Install .....	5
--	---

# REQUIRED ITEMS

- Allen key 6mm
- Ratchet
- 13mm Hex Socket
- Anti Seize (recommended)
- Silicone
- Flat head screwdriver

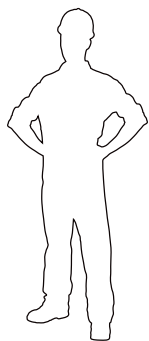

# PHASE 1 – ASSEMBLY

## 1.1 SETUP

1.1.1 Unpack components; compare with the bill of materials.

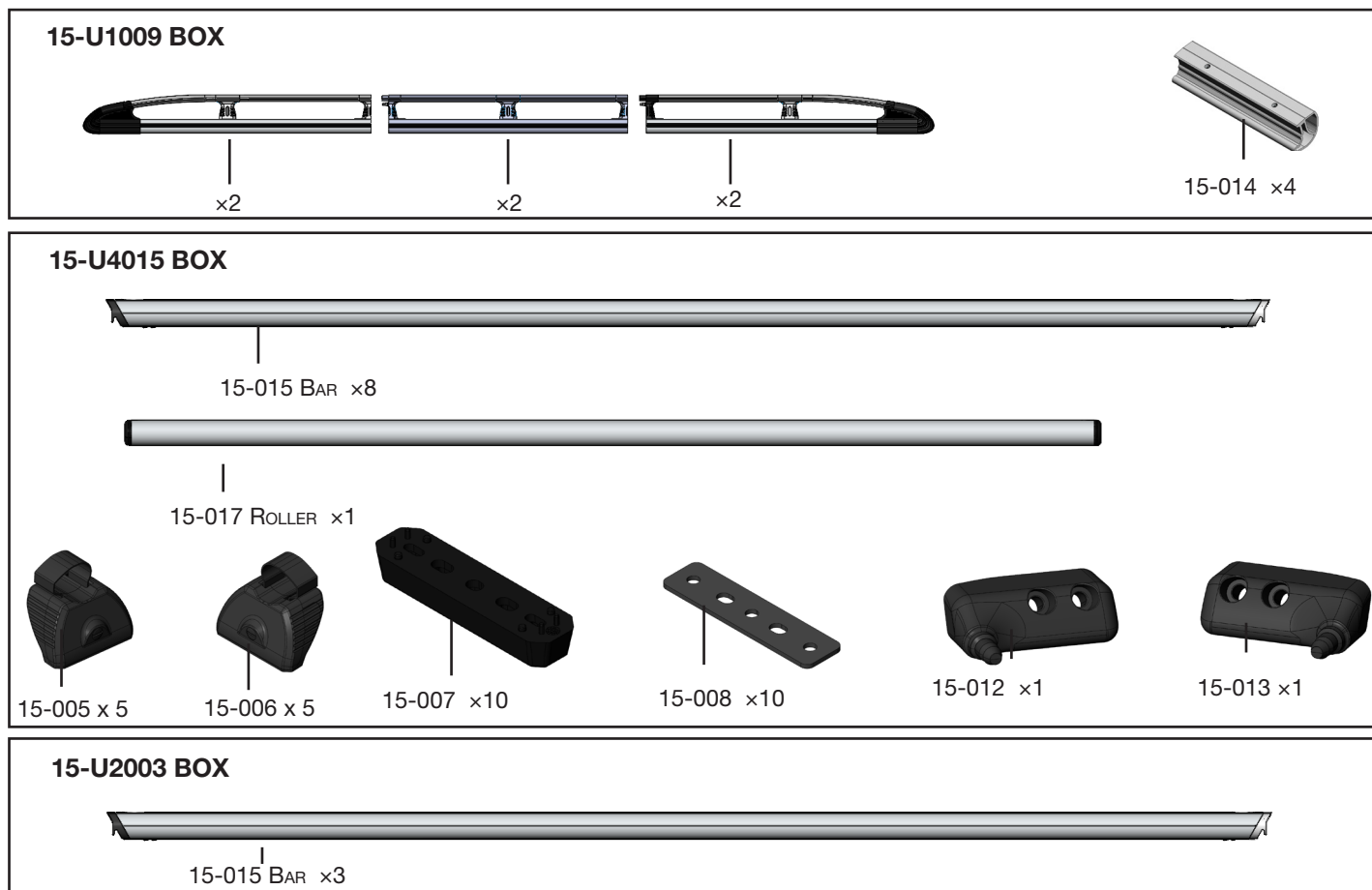

1.1.2 Verify all parts are present

### Bill of Material

Item No.	Description	Qty.
15-005	Cargo+ Foot Passenger Side	5
15-006	Cargo+ Foot Driver Side	5
15-007	Cargo+ Shim	10
15-008	Cargo+ Shim	10
15-012	Cargo+ Driver Side Roller Connection	1
15-013	Cargo+ Passenger Side Roller Connection	1
15-014	Cargo+ Side Rail Connection	4
15-015	Cargo+ Cross bar	11
15-017	Cargo+ Roller	1
98-099	M8 Lock Washer Internal Tooth	10
98-129	M8 Flat Washer	10
90-003	Allen Socket M8 x 25mm	34
90-004	Hex Bolt M8 x 1.25 x 50mm	10
99-010	Cargo+ Side Rail Connector	26

1.1.3 Identify **Assembly** and **Installation** fastener bag.

**Assembly Fastener**

- 34x  # 90-003 Allen Socket M8 x 25mm Rhino Bolt
- 26x  # 99-010 Cargo+ Side Rail Connectors

**Hardware Assembly**

**26x**

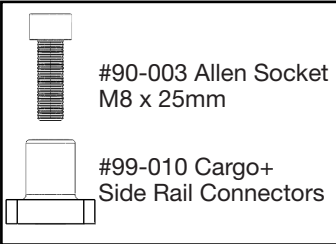

#90-003 Allen Socket M8 x 25mm



#99-010 Cargo+ Side Rail Connectors

**8x**

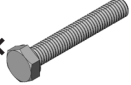

#90-003 Allen Socket M8 x 25mm

**Installation Fastener**

- 10x  #90-004 Hex Bolt M8-1.25x50mm SS304
- 10x  #98-099 Lock Washer M8 Internal Tooth
- 10x  #98-129 Hex Bolt M8 Flat Washer

**Hardware Assembly**

**10x**

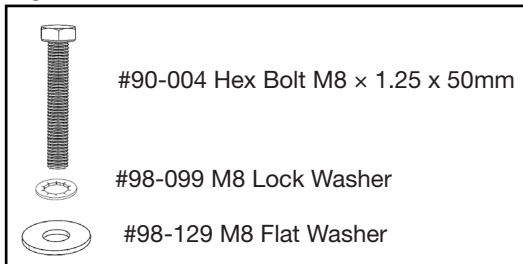

#90-004 Hex Bolt M8 x 1.25 x 50mm

#98-099 M8 Lock Washer

#98-129 M8 Flat Washer

# PHASE 2 – ASSEMBLY

## 1.1 ROOF INSTALLATION

**1.** Remove foot cowlings.

**TOOLS**

- Flat head screwdriver

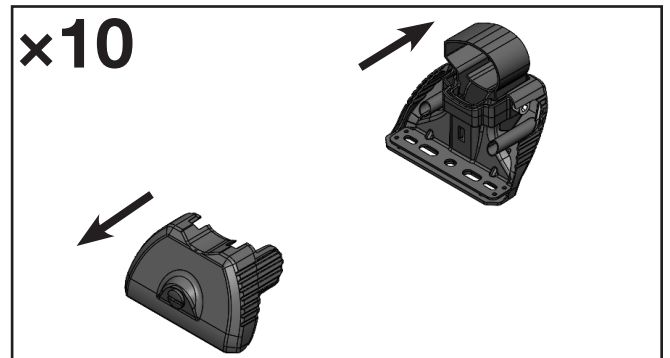
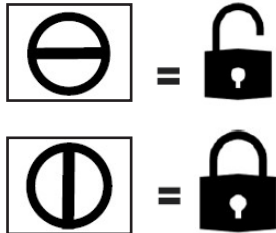

**2.** Install feet to 4 crossbars.

**TOOLS**

- Allen key 6mm

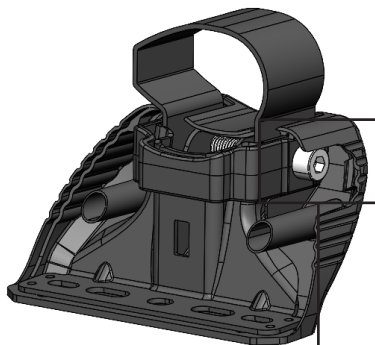

Loosen Bolt

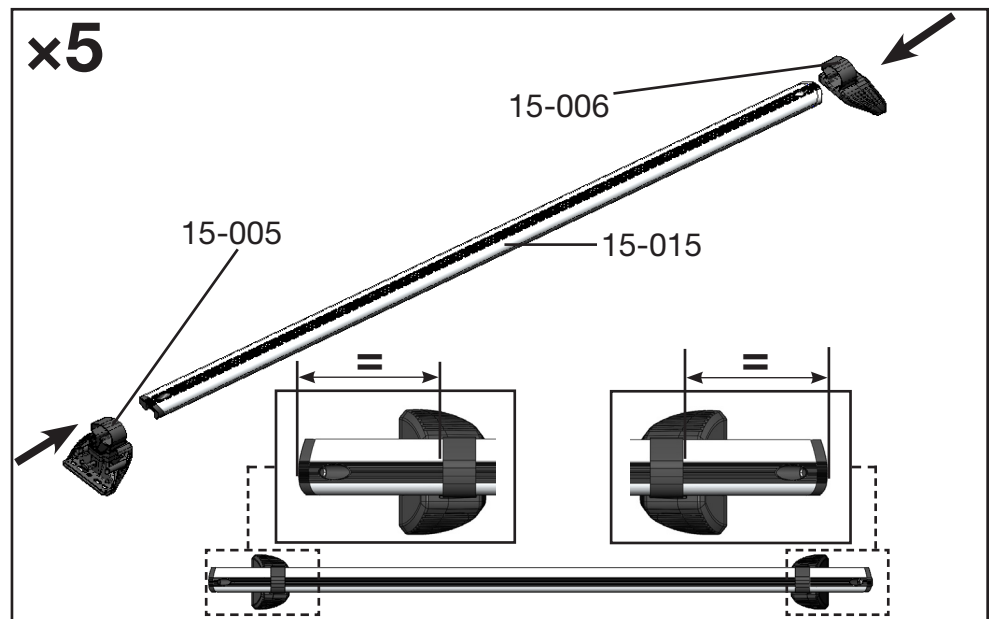

**3.** Prepare roof mounting points by cleaning and applying silicone around each hole.

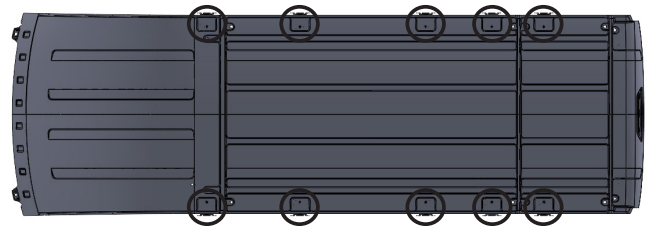
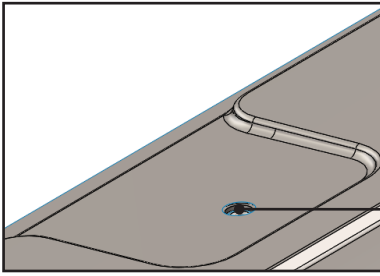

**4.** Mount feet to van mounting points.

**TOOLS**

- ☐ 13mm Hex Socket
- ☐ Ratchet

**HARDWARE USED**

**10x** (12 ft • lbs)

- ☐ #90-004 Hex Bolt M8 x 1.25 x 50mm
- ☐ #98-099 M8 Lock Washer
- ☐ #98-129 M8 Flat Washer

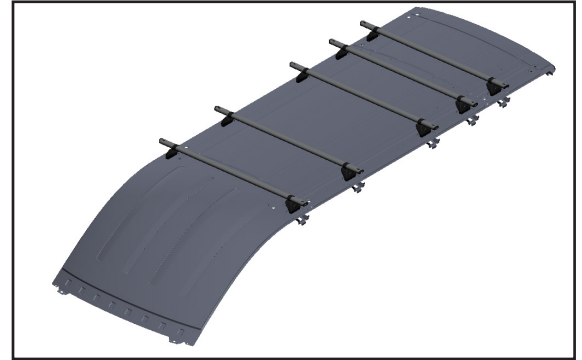
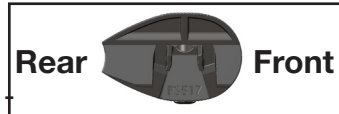
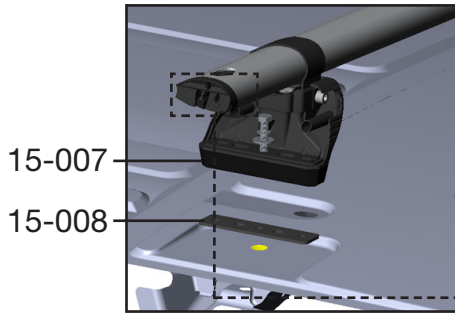

**5.** Assemble both side rails. Use anti-seize as required.

**TOOLS**

- ☐ Allen key 6mm

**HARDWARE USED**

**8x** (7 ft • lbs)

- ☐ #90-003 Allen Socket M8 x 25mm

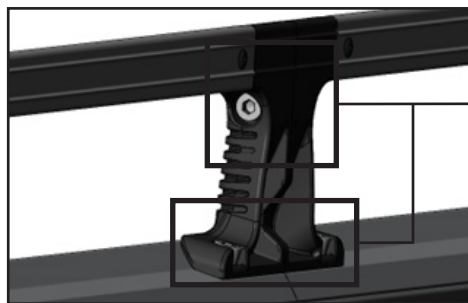
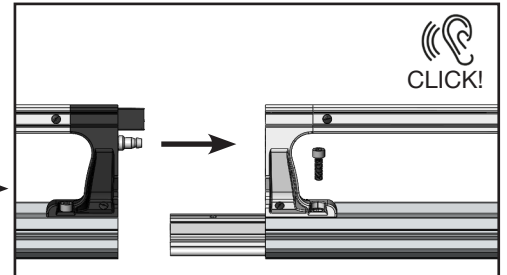
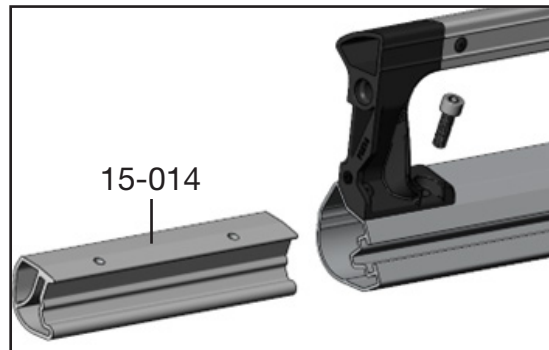

**TIGHTEN**

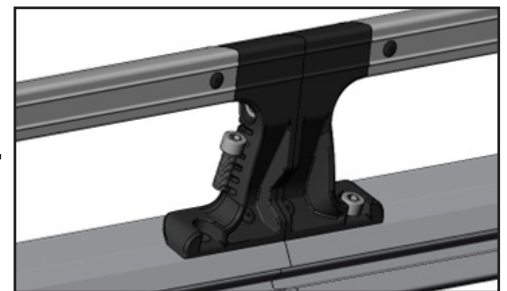

**6.** Assemble roller.

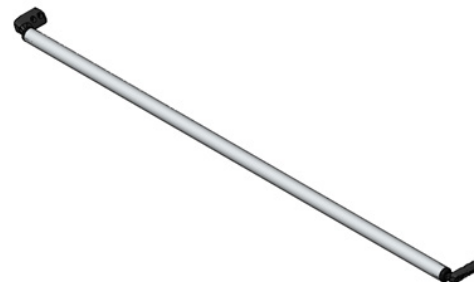
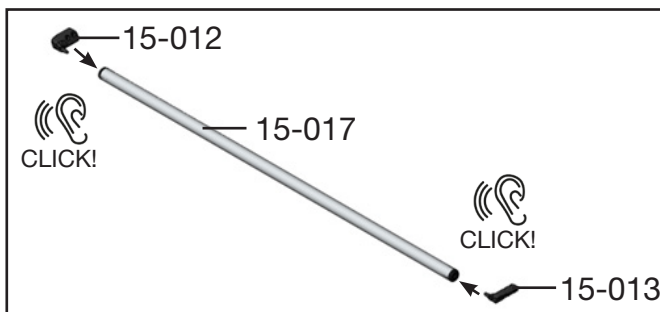

**7.** Install side rail connectors.

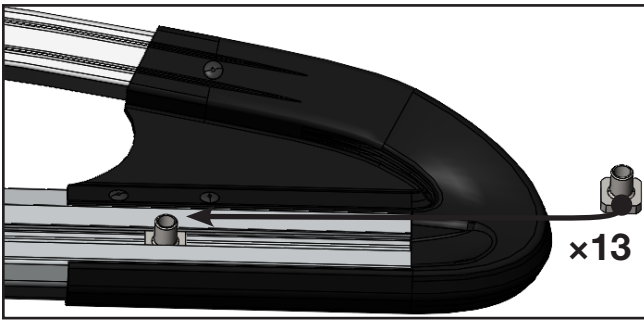

**HARDWARE USED**

**26x**



**8.** Space out the side rail connectors.

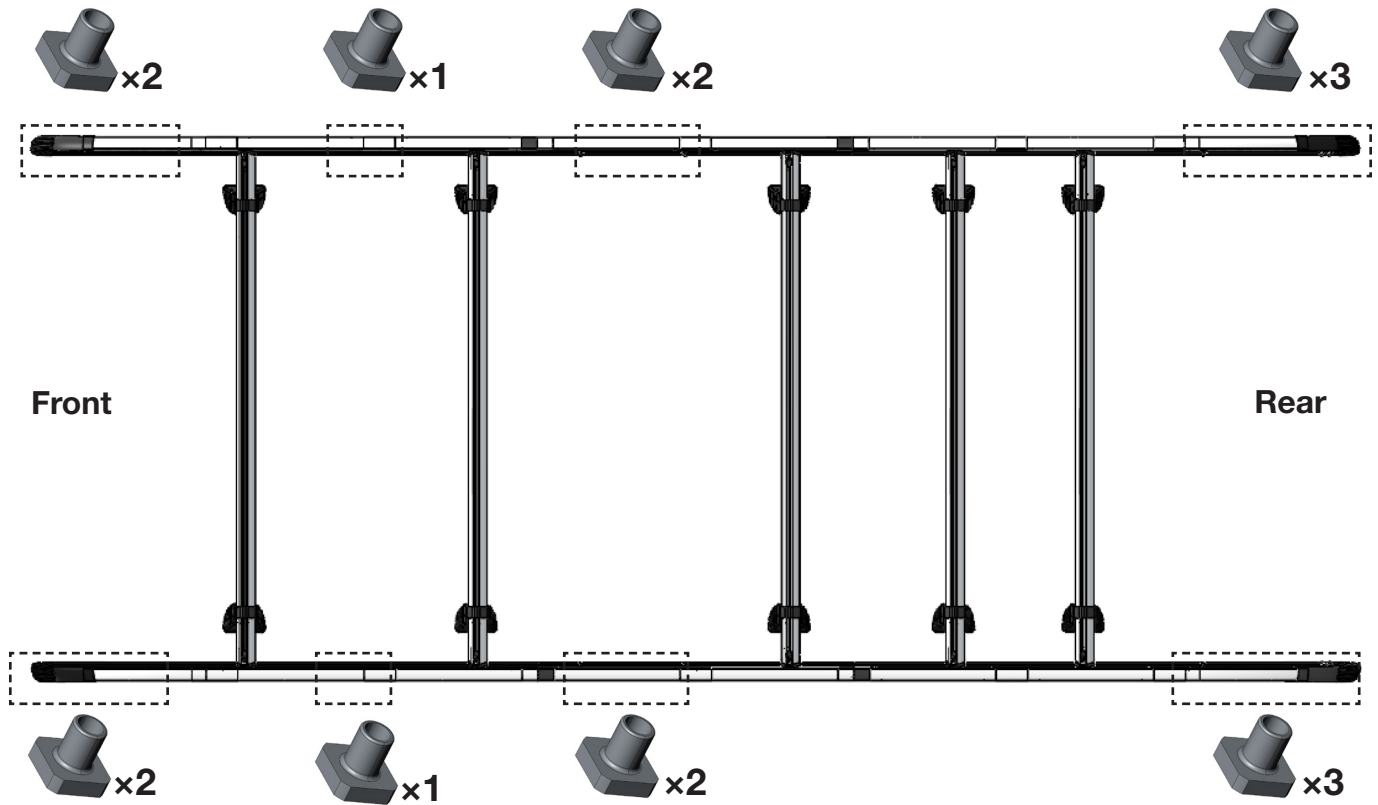

**9.** Mount side rails to crossbars.

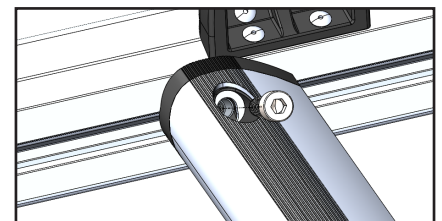
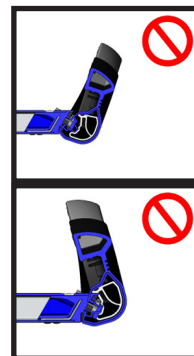
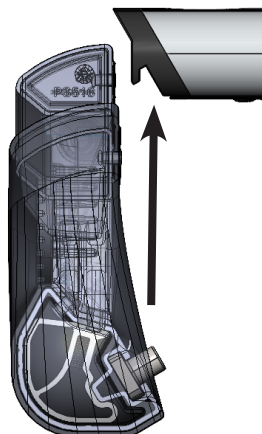
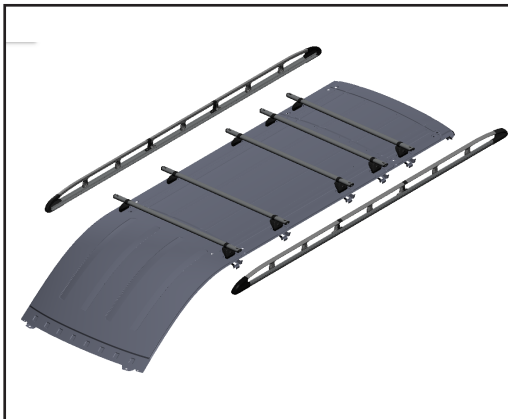

**HARDWARE USED**

**10x** (7 ft • lbs)



**10.** Mount the roller and remaining crossbars, spread out evenly along the side

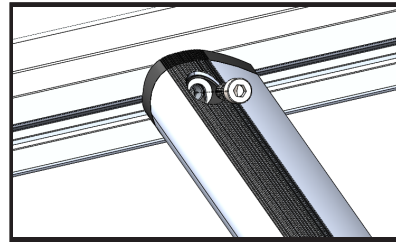
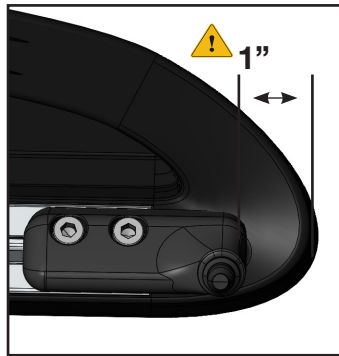
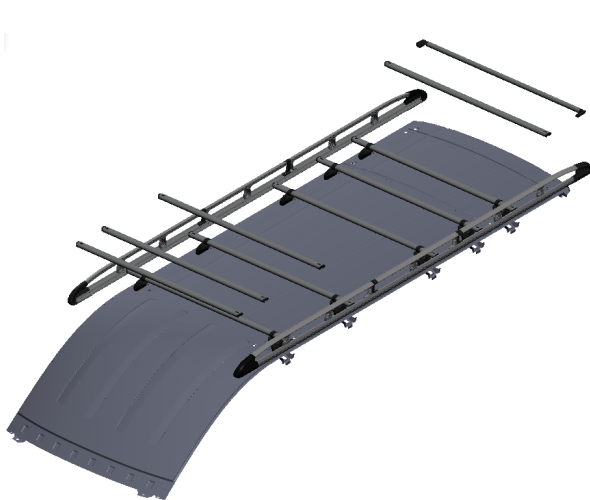

**HARDWARE USED**

**16x** (7 ft • lbs)

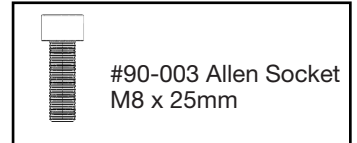

**11.** Tighten all crossbar bolts. Use anti-seize as required.

**TOOLS**

- Allen key 6mm

Verify roller clears rear of van and camera

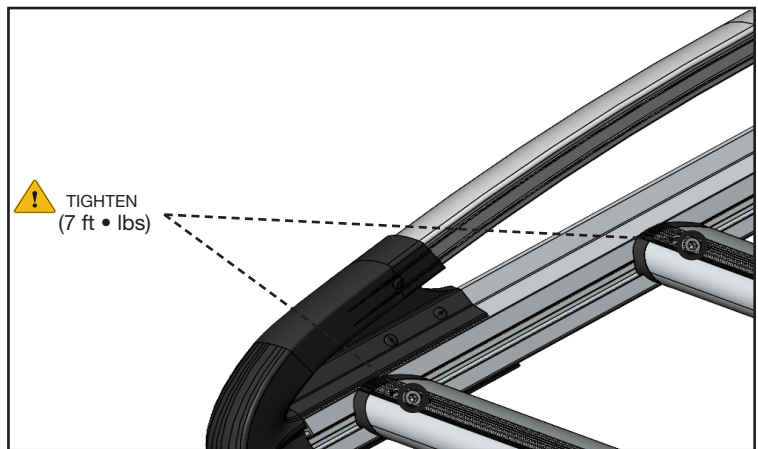
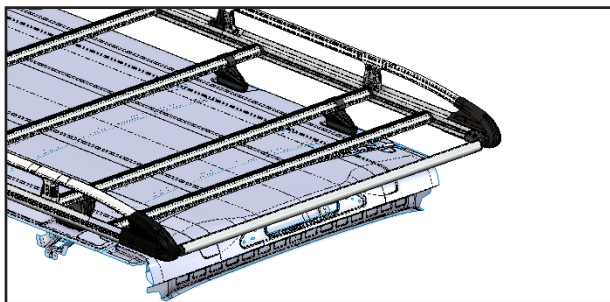

**12.** Re-attach foot cowl.

**TOOLS**

- Flat head screw driver

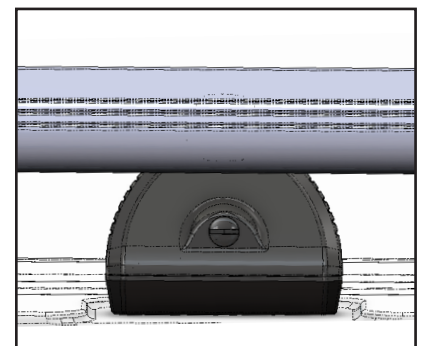
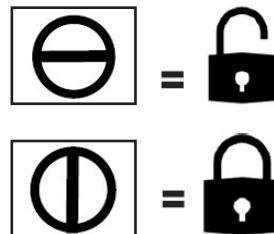
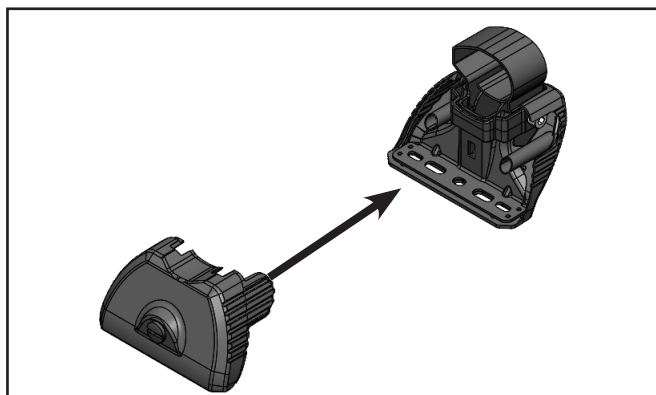

**“You have successfully installed your Cargo +, thank you for doing business with us.”**

For any feedback or suggestions, you may have, please contact: [cs@rangerdesign.com](mailto:cs@rangerdesign.com)